

# OPTIMA-S-PC...BM

Pressure Controller

Handbook

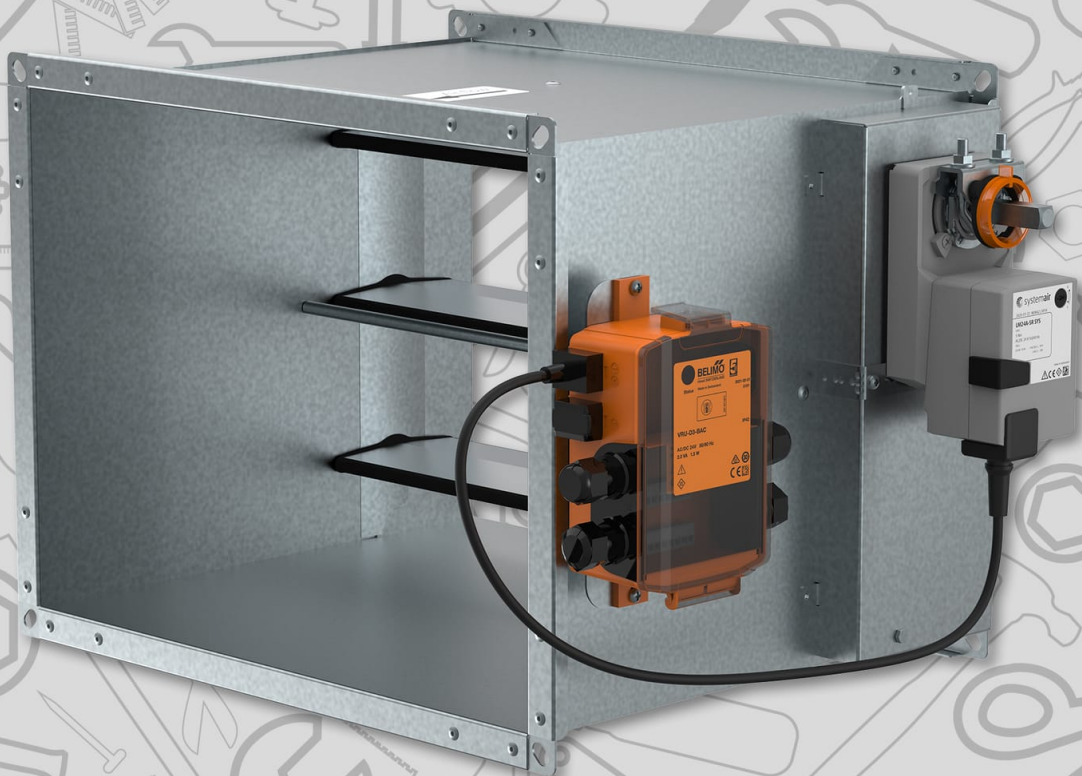

# Table of Contents

Description . . . . .	3
Dimensions & Weights . . . . .	10
Ordering Codes . . . . .	12
Accessories . . . . .	14
Technical Parameters . . . . .	26
Installation . . . . .	27
Electrical Connections . . . . .	30
Transport, Storage and Operation . . . . .	38
Supplement . . . . .	39

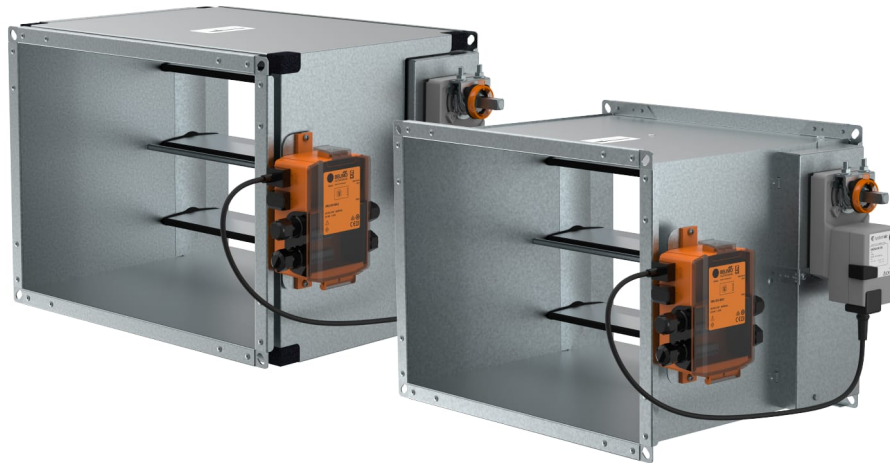

## Description

OPTIMA-S-PC is a variable pressure controller with or without an insulation. The product is intended to control the air pressure in a ventilation system. The product is installed into rectangular ducts. Field of application is e.g. offices, public spaces, laboratories, industrial plants and health care premises.

### Highlights

- Damper tightness class 4 according to EN 1751
- Casing tightness class C according to EN 1751
- High measurement/control accuracy, deviation 5 %
- Pressure control range up to 600 Pa
- Static sensor capable of measurement also in dust polluted atmosphere
- Actuators with quick transition or safety positioning function available
- Insulated version OPTIMA-SI-PC...BM with external insulation for sound reduction

### Types of Product

- **OPTIMA-S-PC...BM**: Non-insulated pressure controller
- **OPTIMA-SI-PC...BM**: Insulated pressure controller

### Type of Controller

- **BM**: Belimo VRU-M1-BAC, pressure range up to 600 Pa with static sensor. Modbus-RTU or BACnet MS/TP switchable port for communication of all variables, analog setpoint and feedback signals DC 0 (2) V ... 10 V applicable

### Types of Actuators

- **S**: Standard actuator
- **Q**: Actuator with short transition time
- **QE**: Actuator with short transition time and electric safety function
- **F**: Actuator with mechanical safety function – spring return

### List of Accessories

- **LDR-A**: Sound Attenuator
- **ZTH-EU**: Handheld Tool

- **ZIP-BT-NFC:** Communication Port Bluetooth/NFC
- **IDC-OPTIMA:** Impulse Tube Duct Connector
- **ITP-OPTIMA:** Impulse Tube
- **ITC-OPTIMA:** Impulse Tube Clamp

## Design

OPTIMA-S-PC...BM is manufactured from galvanized steel sheet. The product consists of a casing, a duct connection, with flange a multiple damper blades with a rubber gasket and a modular pressure control device. OPTIMA-SI-PC...BM is equipped by an insulation for sound reduction. The insulation is a 19 mm thick closed cell foam mat, protected by galvanized steel sheet. The modular pressure control device consists of polyurethane measurement tubes for connection to the pressure impulse tapping spots, an air pressure transmitter, a modular control unit and an actuator.

### Actuators

- **S:** Standard actuator
- **Q:** Actuator with short transition time
- **QE:** Actuator with short transition time and electric safety function

The default manufacturer setting of the actuator safety function is **closing after power supply interruption**.

Upon request the manufacturer setting can be changed to **opening after power supply interruption**. Adjustment of intermediate final safety position (0% ... 100% opening) is possible.

The possibility to change the safety function on site is available.

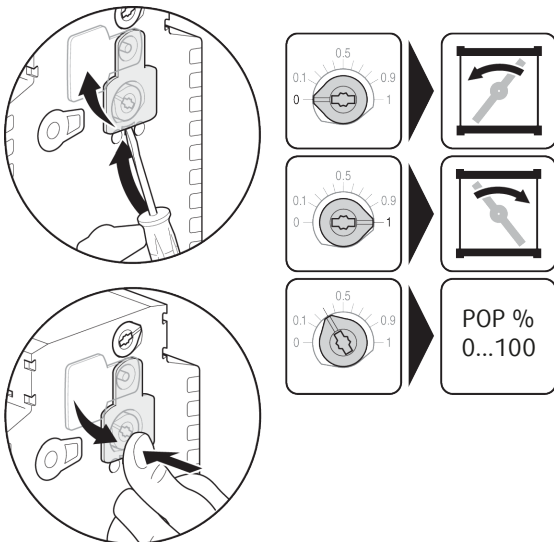

- **F:** Actuator with mechanical safety function – spring return

The default manufacturer setting of the actuator safety function is **closing after power supply interruption**.

Upon request the manufacturer setting can be changed to **opening after power supply interruption**.

		OPTIMA-S(I)-PC...BM																				
		W (mm)																				
		200	250	300	350	400	450	500	550	600	650	700	750	800	850	900	950	1000	1050	1100	1150	1200
H (mm)	T <sub>max</sub> (Nm)	100	4	4	4	4	4	4	4	4	4											
	150	4	4	4	4	4	4	4	4	4	4											
	200	4	4	4	4	4	4	4	4	4	4	5	5	5	5	5						
	250			4	4	4	4	4	4	4	4	5	5	5	5	5	5					
	300			4	4	4	4	4	4	4	4	5	5	5	5	5	5	5	5	5		
	350			4	4	4	4	4	4	4	4	5	5	5	5	5	5	5	5	5	5	
	400					4	4	4	4	5	5	5	5	5	5	5	5	5	5	6	6	6
	450						4	5	5	5	5	5	5	5	5	5	5	5	6	6	6	8
	500							5	5	5	5	5	5	5	5	6	6	6	6	6	8	8
	550								5	5	5	5	5	5	6	6	6	6	8	8	8	8
	600									5	5	6	6	6	6	6	8	8	8	8	8	8
	650										5	6	6	6	6	8	8	8	8	8	8	8
	700											6	6	6	8	8	8	8	8	8	8	8
	750												6	8	8	8	8	8	8	10	10	10
	800													8	8	8	8	8	8	10	10	10
	850														8	8	8	10	10	10	10	10
	900															8	8	10	10	10	10	10
950																10	10	10	10	10	10	
1000																	10	10	10	10	10	

OPTIMA-S(I)-PC...BM-S/Q/QE/F							
S		Q		QE		F	
4	LM24A-VST	4	LMQ24A-VST	4	NKQ24A-VST	4	LF24A-VST
5		5	NMQ24A-VST	5		5	NF24A-VST
6	NM24A-VST	6		6		6	
8		8	8	8			
10		10	SMQ24A-VST	10	-	10	

	∠	⌚	⌚⊗	P <sub>r</sub> (VA)	P (W)
LM24A-VST	90°	⌚/⌚120 s	-	2	1
NM24A-VST	90°	⌚/⌚120 s	-	4	2
LMQ24A-VST	90°	⌚/⌚2,5 s	-	23	13
NMQ24A-VST	90°	⌚/⌚4 s	-	23	13
SMQ24A-VST	90°	⌚/⌚7 s	-	26	15
NKQ24A-VST	90°	⌚/⌚4 s	⌚4 s	22	11
LF24A-VST	90°	⌚/⌚120 s	⌚<20 s	5	2,5
NF24A-VST	90°	⌚/⌚120 s	⌚<20 s	8	5

### Legend



Positioning angle



Transition time



Transition time without power supply (safety function)

$P_r$  (VA)

Power rating (actuator + controller VRU...)

$P$  (W)

Power consumption in operation (actuator + controller VRU...)

## Noise and thermal insulation material for OPTIMA-SI-PC...BM

Base	NBR/PVC
Cellular Structure	Closed
Colour	Black
Density	80 kg/m <sup>3</sup>
Water Absorption	2 % < 5 %
Resistance	Air+ U.V.-Good
Thermal Conductivity (t. + 40 °C)	< 0,039 W/m K
	Class 1 (DM 26/06/84)
	UL 94-HF1
Fire Resistance	Class 0 - BS 476 part6-7 UK
	NF certificate n.38 (until mm.32) France
	B-s3,d0 (EN 13501-1) Euroclass
Marine and Shipbuilding	MED B - MED D - DNV type approval
Steam Diffusion	MU > 7.000
Noise Reduction (DIN 4109)	Up to 30 dB
Ecological Compatibility	NO CFC - HCFC, asbest free

### Controls

The air pressure controllers are equipped by OEM control module and actuator from Belimo. The control units are factory calibrated as standard to the air pressure control range  $P_{\min}$  ...  $P_{\max}$ . The dimension table shows this standard setting.

Upon request the control range  $P_{\min}$  ...  $P_{\max}$  can be adjusted to customized settings prior to dispatch. The pressure limits can also be re-adjusted on site with ZTH-EU hand held service tool. If specific air values for  $P_{\min}$  and  $P_{\max}$  would be required from factory, this must be indicated prior to order of the units for adequate calibration.

## Modular Control/Actuator Unit Functionality Description

Control Module / Actuator Unit	Analog Input	BUS Communication	Parameters Setup	Hard Wired Override	Feedback Signal	Feedback Values	Main BUS Com. Variables	Power Supply
BM-S BM-Q BM-QE BM-F	DC 0 V (2 V) ... 10 V	Modbus-RTU BACnet MS/TP	ZTH-EU ZIP-BT-NFC	OPEN, CLOSE, $P_{min}$ , $P_{max}$	Modbus-RTU BACnet MS/TP DC 0(2) V ... 10 V	Actual pressure, Damper angle	<b>Read/write</b> : Setpoint, $P_{min}$ , $P_{max}$ , OPEN, CLOSE  <b>Read:</b> Actual pressure, damper angle, serial number, fault/alarm messages	AC/DC 24 V



**Product Parts**

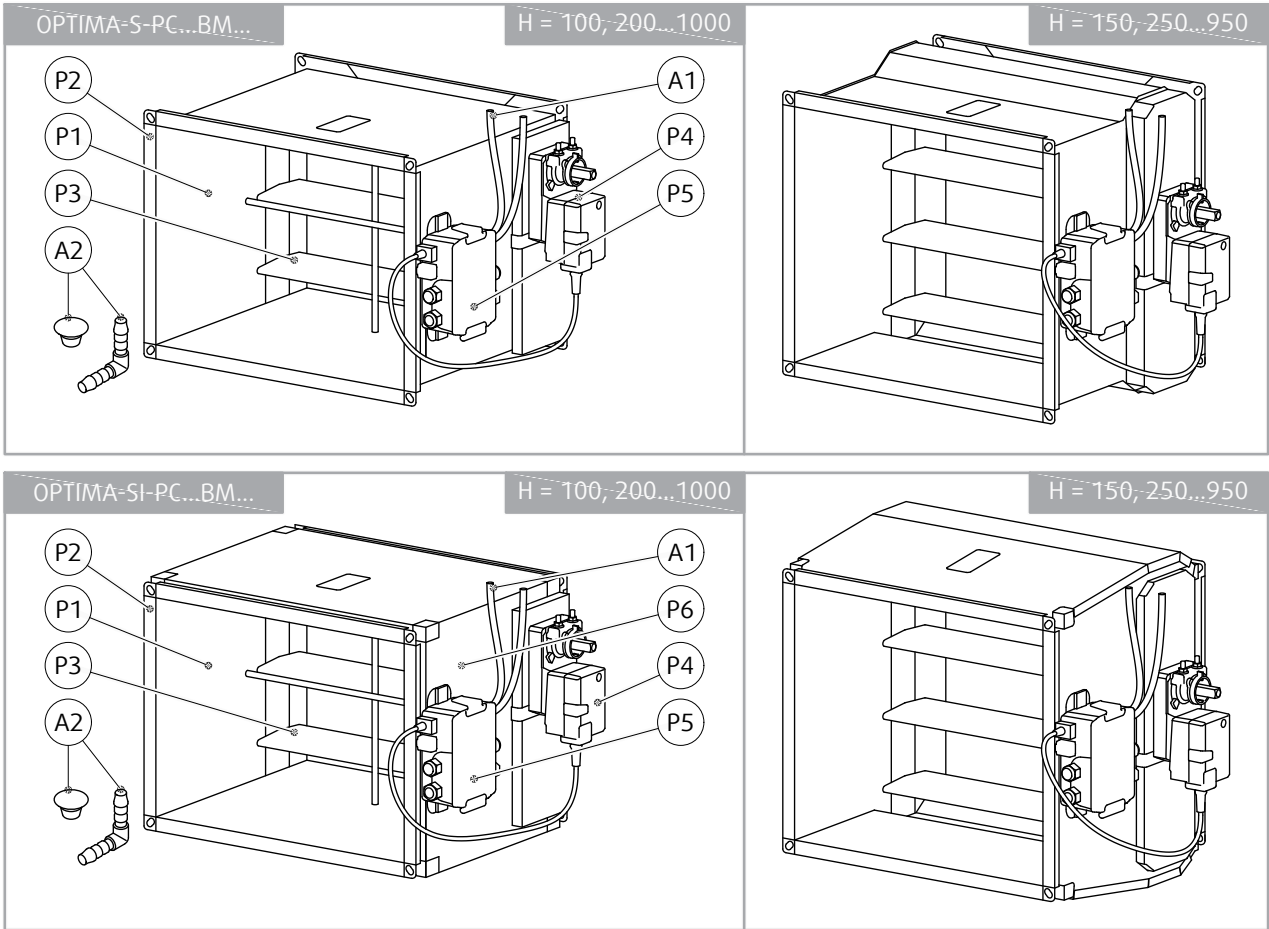

**Legend**

- P1** Casing
- P2** Duct connection flanges
- P3** Damper blade with gasket
- P4** Modular control/actuator unit
- P5** Air flow transmitter
- P6** Insulation
- A1** ITP-OPTIMA (Impulse tube)
- A2** IDC-OPTIMA (Impulse tube duct connector)

# Dimensions & Weights

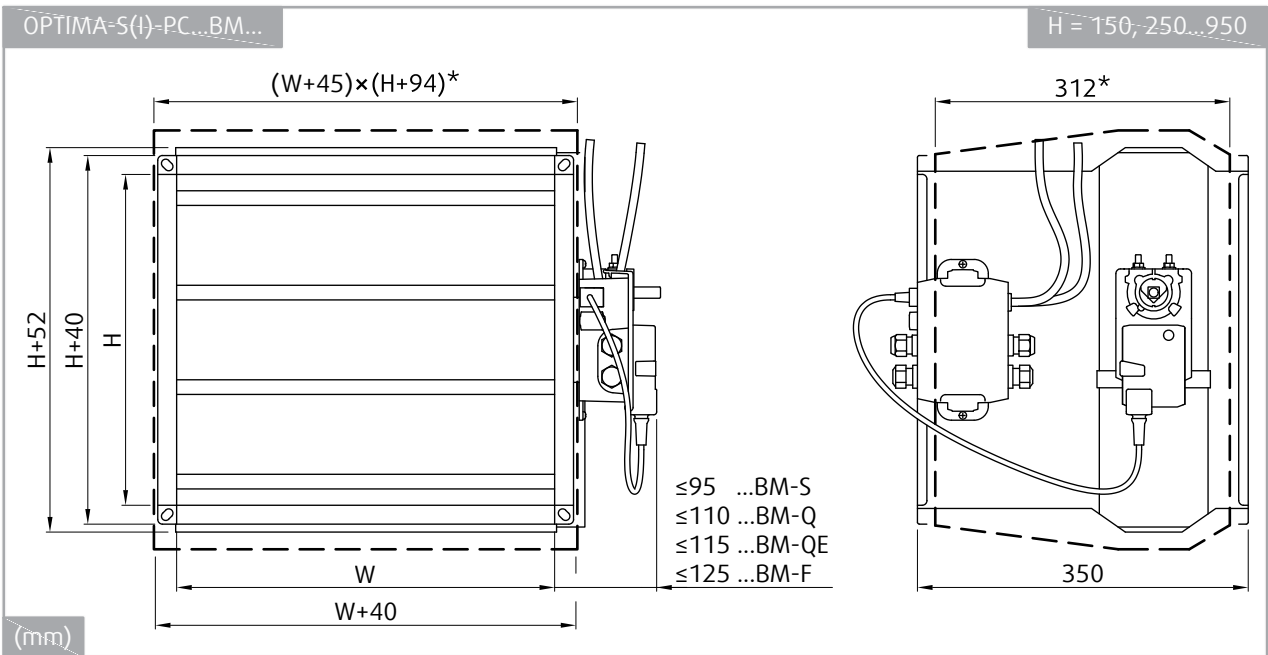
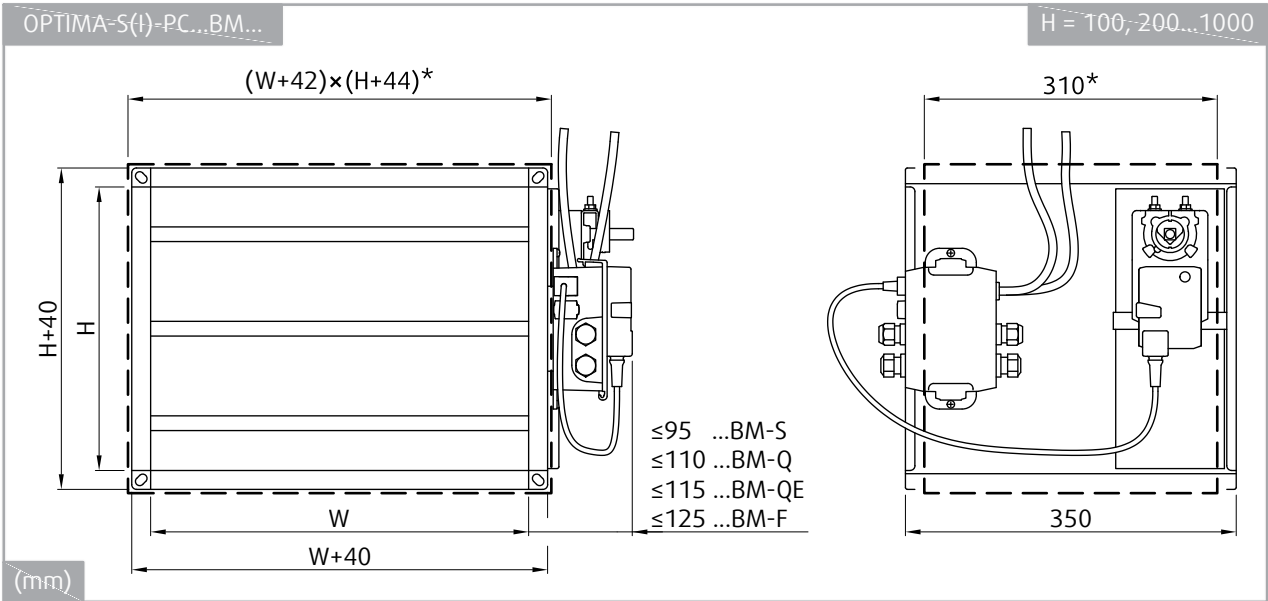

		OPTIMA-S-PC...BM																					
		W (mm)																					
m (kg)		200	250	300	350	400	450	500	550	600	650	700	750	800	850	900	950	1000	1050	1100	1150	1200	
H (mm)	100	4,6	5,1	5,5	5,8	6,1	6,3	6,4	6,9	7,4	-	-	-	-	-	-	-	-	-	-	-	-	
	150	5,8	6,3	6,6	6,5	6,9	7,0	7,2	7,7	8,4	8,8	-	-	-	-	-	-	-	-	-	-	-	
	200	6,2	6,7	7,2	7,4	7,7	7,8	8,2	8,7	9,2	9,7	10,3	10,9	11,3	11,7	12,1	-	-	-	-	-	-	-
	250	-	7,3	7,9	8,0	8,3	9,9	8,7	9,2	10,3	10,8	10,9	11,7	12,4	12,7	12,7	13,0	-	-	-	-	-	-
	300	-	-	8,6	8,8	8,9	9,1	9,6	10,1	10,6	11,2	11,6	12,2	12,7	13,1	13,6	14,0	14,5	14,9	15,3	-	-	-
	350	-	-	9,0	9,5	9,8	10,0	10,2	10,8	11,9	11,7	12,9	13,1	13,8	14,1	14,8	15,1	15,8	16,0	16,5	16,8	-	-
	400	-	-	-	-	10,3	10,5	11,1	11,6	12,1	12,6	13,2	13,7	14,2	14,9	15,5	15,9	16,5	17,1	17,6	18,1	18,5	-
	450	-	-	-	-	-	11,2	11,7	12,3	14,1	13,6	14,3	14,6	15,6	16,0	16,8	17,1	17,9	18,4	19,0	19,4	20,3	-
	500	-	-	-	-	-	-	12,5	13,1	13,6	14,5	15,1	15,5	16,1	16,7	17,3	17,9	18,6	19,2	19,8	20,4	20,9	-
	550	-	-	-	-	-	-	-	13,9	15,9	16,6	17,6	17,6	18,1	18,8	18,8	19,4	20,0	20,7	21,5	21,8	22,7	-
	600	-	-	-	-	-	-	-	-	17,0	17,6	18,2	18,6	19,2	19,8	20,4	21,2	22,0	22,7	23,3	23,9	24,5	-
	650	-	-	-	-	-	-	-	-	-	18,4	19,4	19,5	20,2	20,9	21,1	21,5	22,3	23,0	24,5	24,4	25,3	-
	700	-	-	-	-	-	-	-	-	-	-	20,2	20,5	21,1	21,6	22,3	23,2	24,2	25,0	25,8	26,6	27,4	-
	750	-	-	-	-	-	-	-	-	-	-	-	21,4	22,0	22,5	22,9	23,6	24,6	25,4	27,0	27,0	28,0	-
800	-	-	-	-	-	-	-	-	-	-	-	-	23,0	23,5	24,3	25,2	26,3	27,3	28,2	29,0	29,8	-	
850	-	-	-	-	-	-	-	-	-	-	-	-	-	24,5	24,9	25,8	27,0	27,8	29,0	29,4	30,4	-	
900	-	-	-	-	-	-	-	-	-	-	-	-	-	-	25,7	26,7	27,9	28,9	29,9	30,8	31,9	-	
950	-	-	-	-	-	-	-	-	-	-	-	-	-	-	-	27,9	29,0	30,0	31,0	31,8	32,9	-	
1000	-	-	-	-	-	-	-	-	-	-	-	-	-	-	-	-	29,8	30,9	31,9	32,9	33,8	-	

		OPTIMA-SI-PC...BM																				
		W (mm)																				
m (kg)		200	250	300	350	400	450	500	550	600	650	700	750	800	850	900	950	1000	1050	1100	1150	1200
H (mm)	100	5,9	6,4	7,0	7,5	8,1	8,6	9,2	9,8	10,5	-	-	-	-	-	-	-	-	-	-	-	-
	150	7,2	7,7	8,3	8,4	9,1	9,5	10,1	10,7	11,6	12,1	-	-	-	-	-	-	-	-	-	-	-
	200	7,7	8,3	8,9	9,4	10,0	10,6	11,2	11,8	12,5	13,2	13,9	14,7	15,2	15,8	16,4	-	-	-	-	-	-
	250	-	9,2	9,7	10,1	10,8	12,8	11,9	12,5	13,7	14,4	14,6	15,6	16,5	16,8	17,1	17,8	-	-	-	-	-
	300	-	-	10,4	11,0	11,6	12,3	12,9	13,5	14,2	14,9	15,5	16,3	16,9	17,6	18,2	18,9	19,7	20,5	21,3	-	-
	350	-	-	10,9	11,9	12,7	13,3	13,7	14,4	15,6	15,6	16,9	17,4	18,1	18,6	19,5	20,2	21,2	21,7	22,6	23,3	-
	400	-	-	-	-	13,3	14,0	14,6	15,2	15,9	16,6	17,3	18,1	18,7	19,7	20,4	21,2	22,1	23,0	23,9	24,8	25,7
	450	-	-	-	-	-	14,9	15,4	16,1	18,1	17,7	18,5	19,1	20,3	20,9	21,9	22,5	23,6	24,5	25,5	26,3	27,7
	500	-	-	-	-	-	-	16,3	17,0	17,7	18,7	19,4	20,2	21,0	21,8	22,5	23,5	24,5	25,5	26,5	27,5	28,5
	550	-	-	-	-	-	-	-	17,9	20,1	21,0	22,0	22,5	23,1	24,1	24,1	25,1	26,1	27,1	28,4	29,2	30,6
	600	-	-	-	-	-	-	-	-	21,3	22,1	22,8	23,6	24,4	25,2	26,0	27,1	28,2	29,3	30,4	31,5	32,6
	650	-	-	-	-	-	-	-	-	-	23,1	24,1	24,6	25,5	26,5	26,8	27,6	28,7	29,8	31,8	32,1	33,6
	700	-	-	-	-	-	-	-	-	-	-	25,0	25,8	26,6	27,4	28,2	29,4	30,7	32,0	33,3	34,6	35,9
	750	-	-	-	-	-	-	-	-	-	-	-	26,8	27,6	28,4	28,9	30,0	31,3	32,5	34,6	35,1	36,7
800	-	-	-	-	-	-	-	-	-	-	-	-	28,8	29,6	30,5	31,8	33,2	34,6	36,0	37,4	38,8	
850	-	-	-	-	-	-	-	-	-	-	-	-	-	30,8	31,2	32,6	34,1	35,3	37,0	38,0	39,6	
900	-	-	-	-	-	-	-	-	-	-	-	-	-	-	32,2	33,6	35,1	36,6	38,1	39,6	41,3	
950	-	-	-	-	-	-	-	-	-	-	-	-	-	-	-	35,0	36,4	37,8	39,4	40,8	42,6	
1000	-	-	-	-	-	-	-	-	-	-	-	-	-	-	-	-	37,3	38,9	40,5	42,1	43,7	

# Ordering Codes

## OPTIMA-S-PC...BM

Non-insulated Low Pressure Controller

OPTIMA-S-PC

Nominal Size

W × H

OEM Belimo, Communication Type

**BM** Switchable: Modbus-RTU or BACnet MS/TP or MP-Bus or analog setpoint/feedback DC 0 (2) V ... 10 V

Actuator Type

**S** Standard actuator

**Q** Actuator with short transition time

**QE** Actuator with short transition time and electric safety function (see availability of the actuator for the chosen dimension in the dimension)

**F** Actuator with mechanical safety function – spring return

## OPTIMA-SI-PC...BM

Insulated Low Pressure Controller

OPTIMA-SI-PC

Nominal Size

W × H

OEM Belimo, Communication Type

**BM** Switchable: Modbus-RTU or BACnet MS/TP or MP-Bus or analog setpoint/feedback DC 0 (2) V ... 10 V

Actuator Type

**S** Standard actuator

**Q** Actuator with short transition time

**QE** Actuator with short transition time and electric safety function (see availability of the actuator for the chosen dimension in the dimension)

**F** Actuator with mechanical safety function – spring return

Example of the Ordering Code

**OPTIMA-SI-PC-400x300-BM-F**

Insulated VAV controller, nominal size 400 mm x 300 mm, with spring return safety function actuator.

NOTES:

Standard setup of the control module is Modbus communication.

# Accessories

## LDR-A

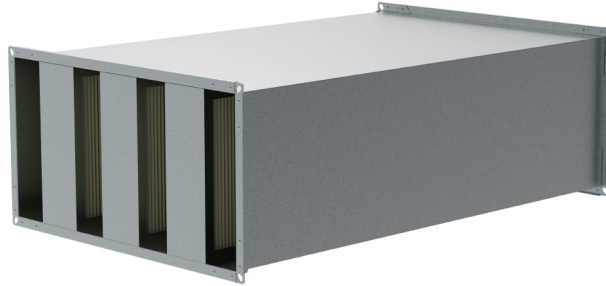

### Description

LDR-A is a sound attenuator for rectangular inline devices. The product is intended for installation in rectangular ducts.

### Design

LDR-A consists of a frame and attenuation inserts. The frame is manufactured from galvanized steel. The inserts are manufactured from mineral wool.

## Product parts

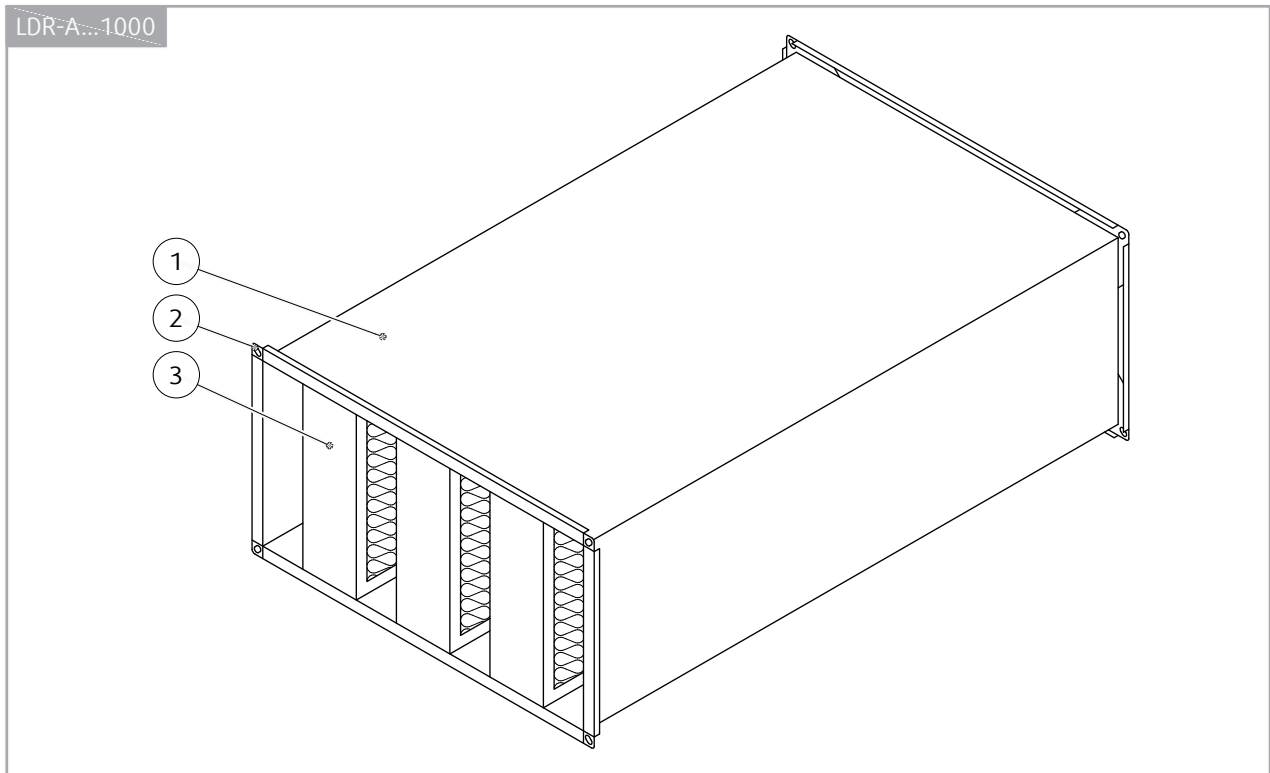

### Legend

**P1** - Attenuator casing

**P2** - Connection flange

**P3** - Attenuation baffle

Dimensions

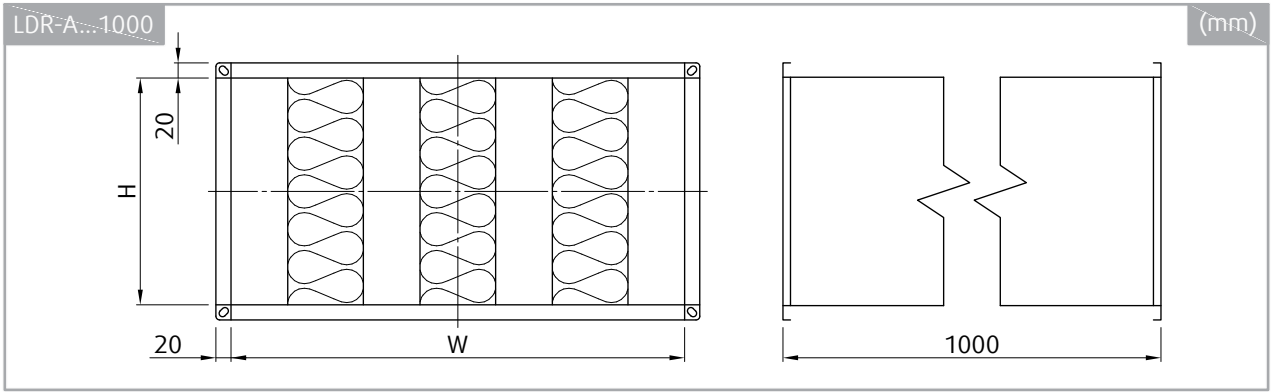



LDR-A			
W	H	L	m
mm			kg
200	100	1000	7
	150	1000	7,5
	200	1000	10,1
250	100	1000	8,4
	150	1000	9,1
	200	1000	11,9
	250	1000	16,2
300	100	1000	9,6
	150	1000	10,9
	200	1000	13,7
	250	1000	18,2
	300	1000	19,2
	350	1000	20,1
350	100	1000	10,9
	150	1000	12,7
	200	1000	15,5
	250	1000	20,3
	300	1000	21,2
	350	1000	22,2
400	100	1000	12,1
	150	1000	14,5
	200	1000	17,3
	250	1000	22,4
	300	1000	23,3
	350	1000	24,3
	400	1000	25,7

LDR-A			
W	H	L	m
mm			kg
450	100	1000	13,4
	150	1000	16,3
	200	1000	19,1
	250	1000	24,4
	300	1000	25,3
	350	1000	26,3
	400	1000	27,8
	450	1000	28,9
500	100	1000	14,6
	150	1000	18,1
	200	1000	20,9
	250	1000	26,5
	300	1000	27,4
	350	1000	28,4
	400	1000	29,1
	450	1000	31,1
550	500	1000	32,3
	100	1000	15,9
	150	1000	19,9
	200	1000	22,7
	250	1000	28,5
	300	1000	29,5
	350	1000	30,4
	400	1000	32,1
	450	1000	33,2
500	1000	34,4	
550	1000	38,1	

LDR-A			
W	H	L	m
mm			kg
600	100	1000	17,1
	150	1000	21,7
	200	1000	24,5
	250	1000	30,6
	300	1000	31,5
	350	1000	32,5
	400	1000	34,3
	450	1000	35,4
	500	1000	36,6
	550	1000	40,6
650	150	1000	23,5
	200	1000	26,3
	250	1000	32,7
	300	1000	33,6
	350	1000	34,6
	400	1000	36,4
	450	1000	37,5
	500	1000	38,7
	550	1000	43,1
	600	1000	44,5
750	250	1000	36,8
	300	1000	37,7
	350	1000	38,7
	400	1000	40,7
	450	1000	41,8
	500	1000	42,1
	550	1000	48,1
	600	1000	49,5
	650	1000	53,1
	700	1000	57,1
750	1000	59,6	

LDR-A			
W	H	L	m
mm			kg
850	200	1000	33,4
	250	1000	40,8
	300	1000	41,7
	350	1000	42,7
	400	1000	44,9
	450	1000	46,0
	500	1000	47,2
	550	1000	53,0
	600	1000	54,4
	650	1000	58,5
	700	1000	63,1
	750	1000	65,6
	800	1000	71,3
	850	1000	73,1
	900	200	1000
250		1000	42,1
300		1000	43,9
350		1000	44,9
400		1000	47,2
450		1000	48,3
500		1000	49,5
550		1000	55,6
600		1000	56,1
650		1000	61,2
700		1000	66,1
750		1000	68,6
800	1000	74,6	
850	1000	76,4	
900	1000	78,4	

LDR-A			
W	H	L	m
mm			kg
950	250	1000	44,1
	300	1000	45,1
	350	1000	46,1
	400	1000	49,3
	450	1000	50,4
	500	1000	51,6
	550	1000	58,1
	600	1000	59,5
	650	1000	63,9
	700	1000	69,1
	750	1000	71,6
	800	1000	77,9
	850	1000	79,7
	900	1000	81,7
950	1000	83,9	
1000	300	1000	47,1
	350	1000	48,1
	400	1000	51,5
	450	1000	52,6
	500	1000	53,8
	550	1000	60,6
	600	1000	61,1
	650	1000	66,6
	700	1000	72,1
	750	1000	74,6
	800	1000	81,2
	850	1000	82,1
	900	1000	84,1
	950	1000	87,2
1000	1000	89,4	

LDR-A			
W	H	L	m
mm			kg
1050	300	1000	50,1
	350	1000	51,1
	400	1000	53,6
	450	1000	54,7
	500	1000	55,9
	550	1000	63,1
	600	1000	64,5
	650	1000	69,3
	700	1000	75,1
	750	1000	77,6
	800	1000	84,5
	850	1000	86,3
	900	1000	88,3
	950	1000	90,5
1000	1000	92,7	
1100	300	1000	52,2
	350	1000	53,1
	400	1000	55,8
	450	1000	56,9
	500	1000	58,1
	550	1000	65,6
	600	1000	66,1
	650	1000	71,1
	700	1000	78,1
	750	1000	80,6
	800	1000	87,8
	850	1000	89,6
	900	1000	91,6
	950	1000	93,8
1000	1000	95,1	

LDR-A			
W	H	L	m
mm			kg
1150	350	1000	55,2
	400	1000	57,9
	450	1000	58,1
	500	1000	60,2
	550	1000	68,1
	600	1000	69,5
	650	1000	74,7
	700	1000	81,1
	750	1000	83,6
	800	1000	91,1
	850	1000	92,9
	900	1000	94,9
	950	1000	97,1
	1000	1000	99,3
1200	400	1000	60,1
	450	1000	61,2
	500	1000	62,4
	550	1000	70,6
	600	1000	71,1
	650	1000	77,4
	700	1000	84,1
	750	1000	86,6
	800	1000	94,4
	850	1000	96,2
	900	1000	98,2
	950	1000	100,4
1000	1000	102,6	

## ZTH-EU

Handheld Tool



ZTH-EU is a handheld tool for VAV controllers and communicative actuators. The product enables the customer to change the configuration of the VAV controllers.

## ZIP-BT-NFC

Communication Port Bluetooth/NFC



ZIP-BT-NFC is a wireless interface connecting the smartphone with configuration app Belimo Assistant via Bluetooth to the VAV controller VRU... with NFC communication protocol.



## IDC-OPTIMA

### Impulse Tube Duct Connector



#### Description

IDC-OPTIMA is an impulse tube duct connector for differential pressure tapping on the ventilation duct. The product can be also used for ending and mechanical fixing of the impulse tube on other places foreseen for pressure tapping. In such case the use of the rubber gasket is not necessary.

Package unit: 2 connectors

#### Ordering Code

IDC-OPTIMA

## ITP-OPTIMA

### Impulse Tube



#### Description

ITP-OPTIMA is an impulse tube for connection between differential pressure tapping spots and pressure transmitter.

#### Ordering Code

ITP-OPTIMA-L <sup>1)</sup>

#### NOTES:

<sup>1)</sup> L: Length (m), 3 lengths are available: 2 m, 5 m, 10 m

Package unit: length (m)

Maximum recommended length for one impulse tube: 10 m.

Both impulse tubes must have the same length.

## ITC-OPTIMA

### Impulse Tube Clamp



### Description

ITC-OPTIMA is an impulse tube clamp. The product is intended to fix the impulse tubes in the installation position. ITC-OPTIMA helps to avoid mechanical stress and deformation of the tube. It is recommended to fix the impulse tubes at least every 1,5 m of the length.

### Ordering Codes

ITC-OPTIMA-n

#### NOTES:

Impulse tube clamps in package units with n pieces of clamps.

n = 2 (package with 2 pieces)

n = 6 (package with 6 pieces)

n = 10 (package with 10 pieces)

# Parametrisation

Configuration with ZTH-EU or by Belimo Assistant app via NFC or via Bluetooth through ZIP BT NFC

			Tool		Authorisation
Parameter/Function	Unit/Value	Function/Description/ (Area)	Assistant App	ZTH-EU	Expert/OEM
<b>VAV Unit/Air Duct Pressure Control Butterfly Valve - Manufacturer Parameters (OEM Values - Not Variable)</b>					
OSN Actuator	xxxxx-xxxxx-xxx-xxx	Actuator series number	r	-	
Rotation Direction	CCW/CW	Actuator direction of rotation setting	r/w	-	E
Range of rotation	Adapted/programmed	Actuator adapted/programmed 30°...95°	r/w	-	E
Power on behaviour	No action/synch. / adaption	Actuator power on behaviour	r/w	-	E
<b>Parametrisation - Project-specific Settings</b>					
Position	Text string	Plant designation (64 Z./ZTH 16 Z.)	r/w	r	
Max	m <sup>3</sup> /h   l/s   cfm (PC-tool/ ZTH %) % (position)	Operating volumetric flow 0% ... 100% V <sub>nom</sub> Damper position (pos. ctrl.) 0% ... 100%	r/w	r/w	
Min	m <sup>3</sup> /h   l/s   cfm (PC-tool/ ZTH %) % (position)	Operating volumetric flow 0% ... 100% V <sub>nom</sub> Damper position (pos. ctrl.) 0% ... 100%	r/w	r/w	
Altitude compensation	ON/OFF	Switch function ON/OFF	r/w	-	E
Altitude of installation	0 m	Compensated Δp and volumetric flow values to set the altitude of installation (above sea level)	r/w	-	E
Function	VAV-CAV/position control	Control function	r/w	-	E
Setpoint	Analogue/bus	Analogue and hybrid mode/bus	r/w	-	E
Setpoint offset	0	VAV: ±5% compensation ABL unit	r/w	-	E
Reference signal Y	2 V ... 10 V/0 V ... 10 V/ adjustable	Setting for VAV control	r/w	-	E
Feedback type	Volumetric flow/Δp/ position	VAV: volume/Δp/damper position Pressure: Δp/damper position	r/w	-	E
Feedback U	2 V ... 10 V/0 V ... 10 V/ adjustable	Setting U signal	r/w	-	E



## Bus parameter

			Tool		Authorisation
Parameter/Function	Unit/Value	Function/Description/ (Area)	Assistant App	ZTH-EU	Expert/OEM
<b>Parametrisation – Communication</b>					
Bus protocol	BACnet MS/TP / Modbus / MP		r/w	–	E
Bus protocol	BACnet MS/TP				
MAC address	0...127		r/w	–	E
Baudrate	9600 / ... / 115200		r/w	–	E
Terminating resistor	OFF/ON		r/w	–	E
Instance number	1...4194304		r/w	–	E
Device name	VAV universal	(32 Z.)	r/w	–	E
Max master	1...127		r/w	–	E
Bus protocol	Modbus RTU				
Address	1...247		r/w	–	E
Baudrate	9600 / ... / 115200		r/w	–	E
Terminating resistor	OFF/ON		r/w	–	E
Parity	1-8-N-2/...E-1/...-0-1/...- N-1		r/w	–	E
Bus protocol	MP-Bus				
MP address	PP/MP1...8	PP (MP off)/MP1...8	r/w	–	E
Bus fail position	0	0% ... 100% (min...max)	r/w	–	E
Compatibility mode	Default/VRP-M	Default: Belimo MP datapool device VRP-M: VRP-M replacement in existing MP system	r/w	–	E

**Legend****X** Application supports function**r** Tool: read**w** Tool: write

– Tool: Does not support parameter

**E** Only visible in Expert Mode Authorisations - functionally relevant settings are only accessible via the Expert Level of the Belimo Assistant App.

# Technical Parameters

Diagrams and technical parameters are available at [design.systemair.com](https://design.systemair.com) (product OPTIMA-S-PC...BM).

# Installation

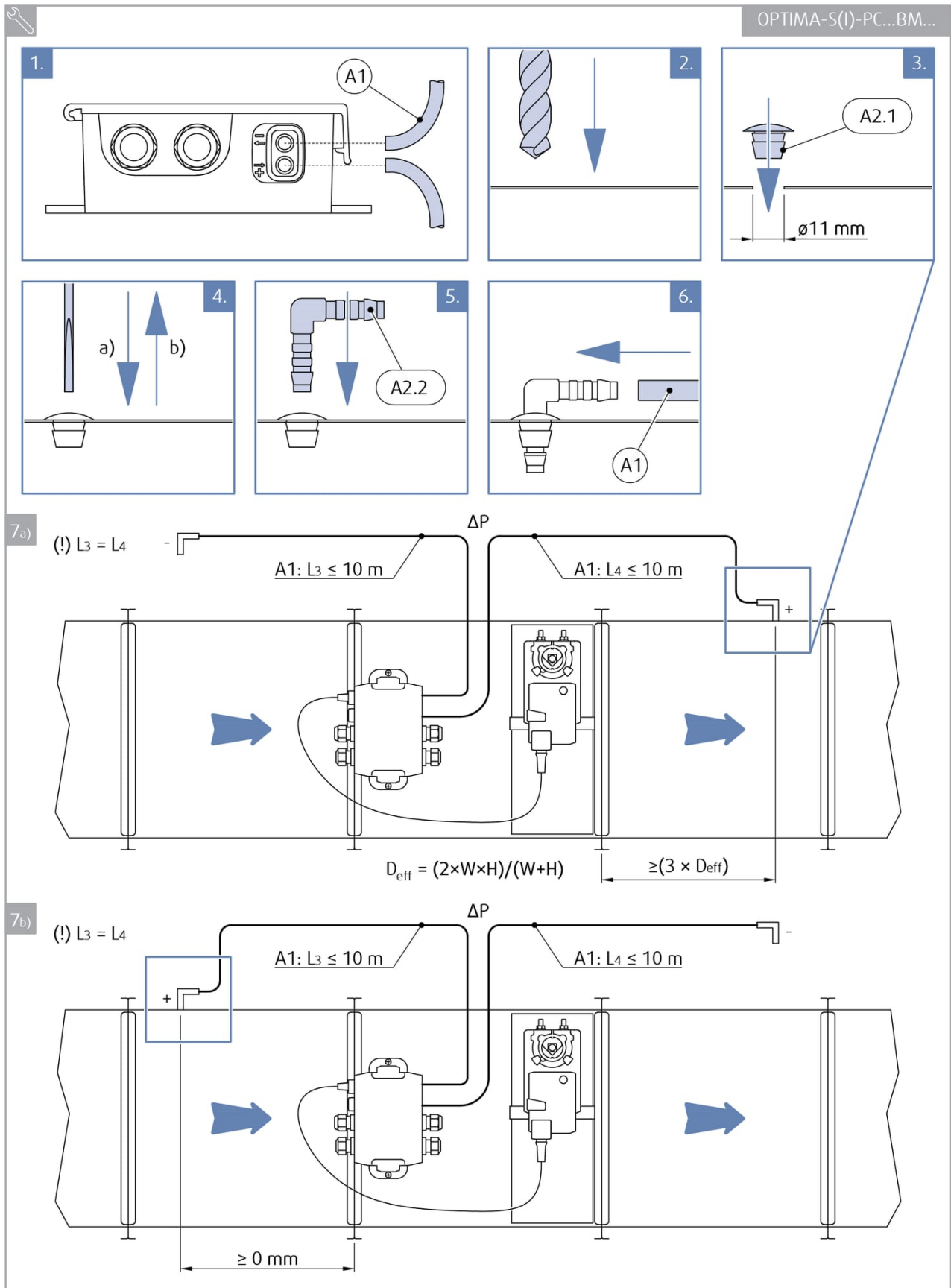

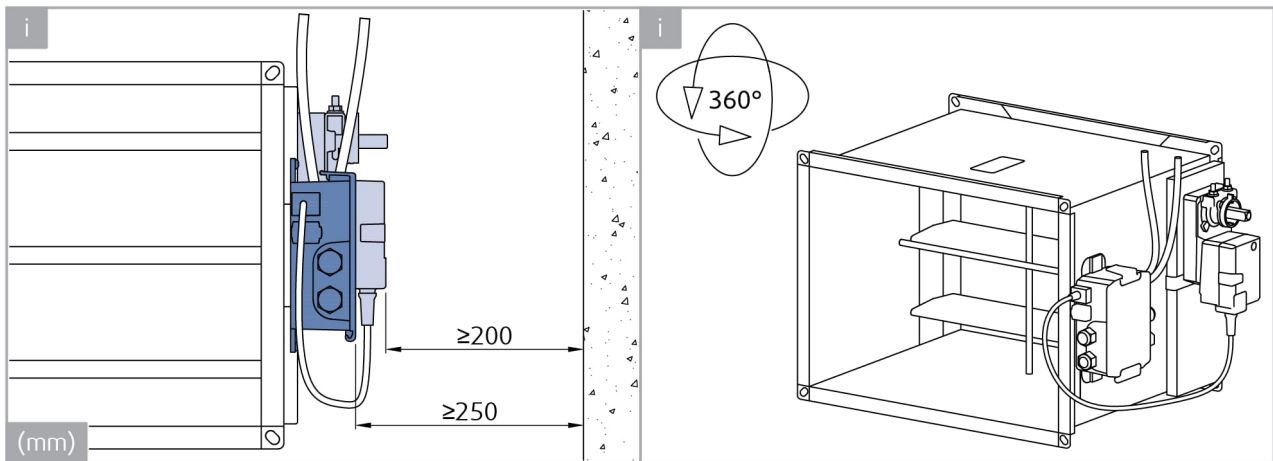

Legend:

- A1** ITP-OPTIMA (Impulse tube)
- A2** IDC-OPTIMA (Impulse tube duct connector)
- A2.1** Gasket
- A2.2** Impulse tube duct connector

# Control strategies

OPTIMA-R(-S)-PC...

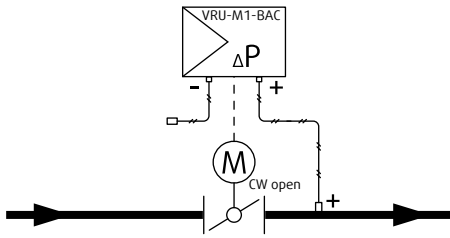

Controlling the pressure after the control damper: The damper increases opening with increasing control value.

OPTIMA-R(-S)-PC...

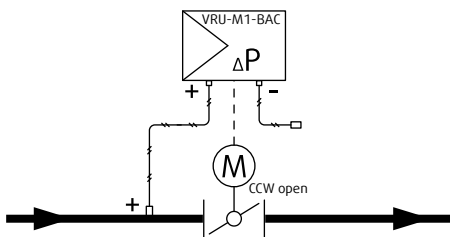

Controlling the pressure in front of the control damper: The damper decreases opening with increasing control value.

# Electrical Connections

## AC/DC 24 V, modulating (Pressure control)

The  $\Delta P$  controller operates with setpoint adjusted through analog input signal (terminal 3) and feedback signal (terminal 5).

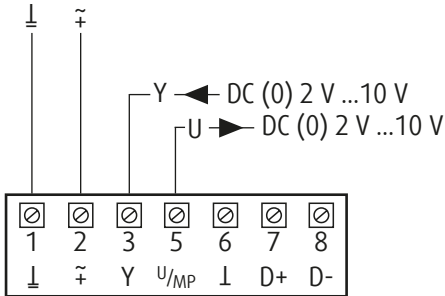

Additional functions can be activated by connecting the override inputs z1 and z2.

The priority of these functions is higher than the  $\Delta P$  modulating operation with analog input.

Override control z1

Contact 11-9 = Motor STOP

Contact 11-10 = Damper OPEN

Override control z2

Contact 12-13 = Damper CLOSED

Contact 12-14 =  $P_{\max}$

11 and 12 without contact = no priority override through z1 or z2

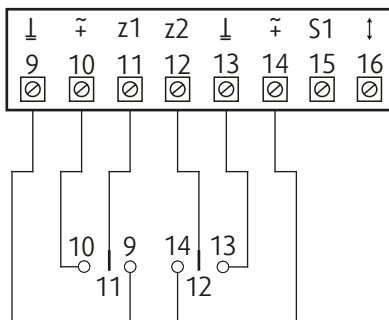

Priority rule - Analog  $\Delta P$  control

1. z1
2. z2
3. a) adaption (autonomous initializing controller function)
4. b) synchronisation (autonomous initializing controller function)
5. Y-Modulating:  $P_{\min} \dots P_{\max}$  (through analog input)

**AC/DC 24 V, contactor step control (Constant pressure control)**

The ΔP controller operates with setpoint in discrete steps generated by different potentials connected to the analog input (terminal 3) and analog feedback signal (terminal 5).

Contact 2-3 =  $P_{max}$

3 not connected =  $P_{min}$

Contact 1-3 = damper CLOSE (control signal mode 2...10V)

Contact 1-3 =  $P_{min}$  (control signal mode 0...10 V)

The control signal mode can be adjusted in the ΔP controller by the handheld configuration tool ZTH-EU.

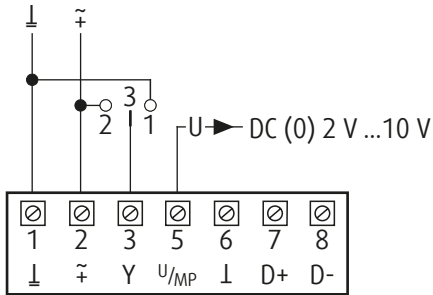

Additional functions can be activated by connecting the override inputs z1 and z2.

The priority of these functions is higher than the ΔP modulating operation with analog input.

Override control z1

Contact 11-9 = Motor STOP

Contact 11-10 = Damper OPEN

Override control z2 Contact 12-13 = Damper CLOSED

Contact 12-14 =  $P_{max}$

11 and 12 without contact = no priority override through z1 or z2

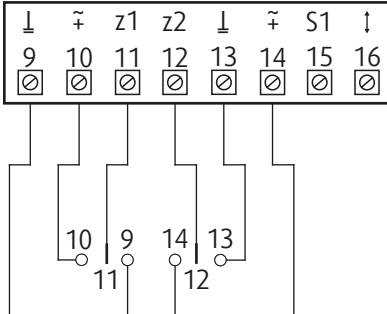

Priority rule - Step-Control

1. z1
2. z2
3. a) adaption (autonomous initializing controller function)
4. b) synchronisation (autonomous initializing controller function)
5. Y-Step Control: Close –  $P_{min}$  -  $P_{max}$  (through analog input)

**BACnet MS/TP or Modbus RTU**

(This operation mode requires parametrization)

$\Delta P$  control in  $P_{min} \dots P_{max}$  range and other functionalities with all variables communicated through bus (terminals 7, 8) – by Modbus or BACnet protocol.

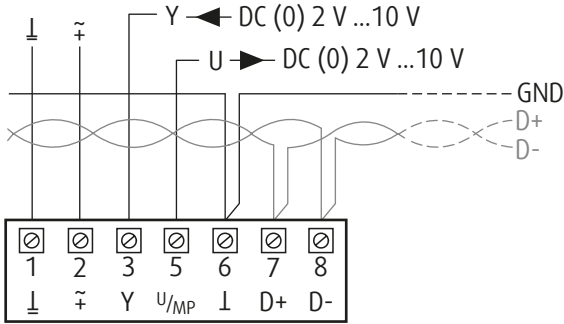

Additional functions can be activated by connecting the override inputs z1 and z2.

The priority of these functions is higher than the  $\Delta P$  modulating operation with analog input.

Override control z1

Contact 11-9 = Motor STOP

Contact 11-10 = Damper OPEN

Override control z2

Contact 12-13 = Damper CLOSED

Contact 12-14 =  $P_{max}$

11 and 12 without contact = no priority override through z1 or z2

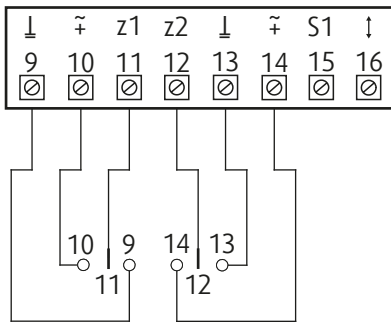

Priority rule – BACnet / Modbus Control

1. z1
2. z2
3. Bus Watchdog
4. a) adaption (autonomous initializing controller function)
5. b) synchronisation (autonomous initializing controller function)
6. Bus Override
7. Bus Setpoint:  $P_{min} \dots P_{max}$



**BACnet MS/TP or Modbus RTU with analog setpoint (hybrid mode)**

(This operation mode requires parametrization)

$\Delta P$  control in  $P_{\min} \dots P_{\max}$  range and other functionalities with setpoint reading through analog input (terminal 3) and feedback through analog output (terminal 5). All other variables are communicated through bus (terminals 7, 8) – by Modbus or BACnet protocol.

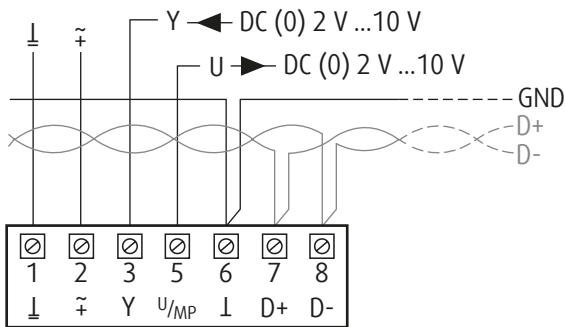

Additional functions can be activated by connecting the override inputs z1 and z2.

The priority of these functions is higher than the  $\Delta P$  modulating operation with analog input.

Override control z1

Contact 11-9 = Motor STOP

Contact 11-10 = Damper OPEN

Override control z2

Contact 12-13 = Damper CLOSED

Contact 12-14 =  $P_{\max}$

11 and 12 without contact = no priority override through z1 or z2

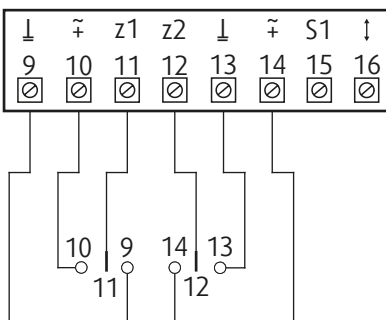

Priority rule – BACnet / Modbus Control

1. z1
2. z2
3. Bus Watchdog
4. a) adaption (autonomous initializing controller function)
5. b) synchronisation (autonomous initializing controller function)
6. Bus Override
7. Y-Step Control: Close –  $P_{\min}$  -  $P_{\max}$  (through analog input – see wiring for AC/DC 24V Step Control)
8. Y-Modulating:  $P_{\min} \dots P_{\max}$  (through analog input – see wiring for Modulating VAV)

**MP-Bus**

(This operation mode requires parametrization)

$\Delta P$  control in  $P_{\min} \dots P_{\max}$  range and other functionalities with all variables communicated through bus (terminals 1, 2, 5) – by MP-Bus protocol.

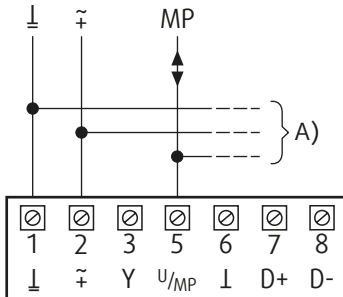

Additional functions can be activated by connecting the override inputs z1 and z2.

The priority of these functions is higher than the  $\Delta P$  modulating operation with analog input.

Override control z1

Contact 11-9 = Motor STOP

Contact 11-10 = Damper OPEN

Override control z2

Contact 12-13 = Damper CLOSED

Contact 12-14 =  $P_{\max}$

11 and 12 without contact = no priority override through z1 or z2

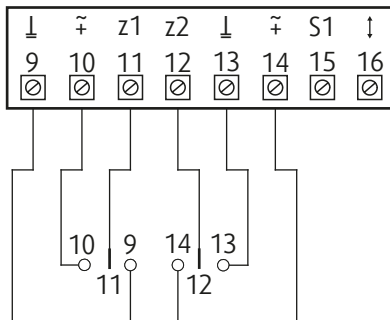

Priority rule – BACnet / Modbus Control

1. z1
2. z2
3. Bus Watchdog
4. a) adaption (autonomous initializing controller function)
5. b) synchronisation (autonomous initializing controller function)
6. Y-Step Control: Close –  $P_{\min}$  -  $P_{\max}$  (through analog input – see wiring for AC/DC 24V Step Control)
7. Bus Override
8. Bus Setpoint:  $P_{\min} \dots P_{\max}$

**Connection of passive sensor**

(Available in bus operation)

The value measured by the passive sensor can be communicated as a variable by bus.

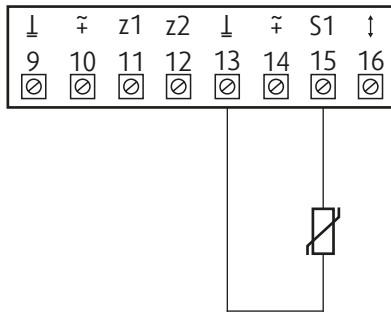

Suitable for Ni1000 and Pt1000

**Connection of active sensor**

(Available in bus operation)

The value measured by the active sensor can be communicated as a variable by bus.

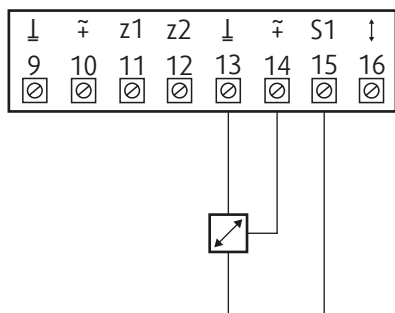

Possible input voltage range:

DC 0...10 V (resolution 5 mV)

Example:

- Active temperature sensors
- setpoint generator
- humidity sensor

**Connection switching contact**

(Available in bus operation)

The binary value of the switching contact can be communicated as a variable by bus.

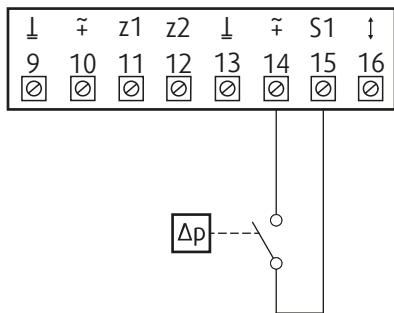

Requirements switching contact: The switch must be capable of switching a current of 10 mA @ 24 V cleanly.

Example:

- dP sensor
- window contact

# Transport, Storage and Operation

Transport and storage temperature range: -20 °C to +40 °C, dry indoor conditions.

Operation temperature range: -20 °C ... +70 °C in the duct, -20 °C ... +50 °C on the actuator.

# Supplement

Any deviations from the technical specifications contained herein and the terms should be discussed with the manufacturer. We reserve the right to make any changes to the product without prior notice, provided that these changes do not affect the quality of the product and the required parameters.

Current information on all products is available on [design.systemair.com](http://design.systemair.com).

