

OPTIMA-S-FC...BM

VAV Controller, Belimo Modbus Modular

Handbook



Table of Contents

Description	3
Dimensions & Weights	10
Ordering Codes	12
Accessories	14
Quick Selection	24
Technical Parameters	28
Installation	29
Electrical Connections	30
Transport, Storage and Operation	38
Supplement	39

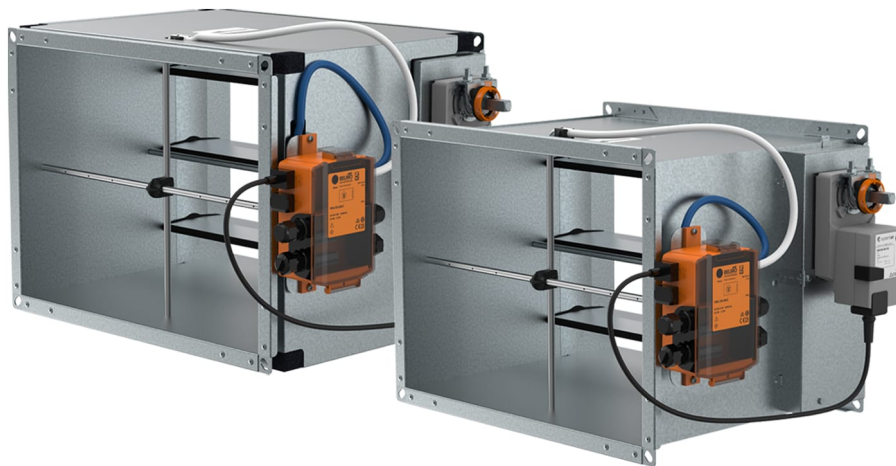

Description

OPTIMA-S-FC...BM is a variable air volume controller with or without an insulation. The product is intended to control the flow volume of supply or return air. The product is installed into rectangular ducts. The product is ideal for all applications, where a variable air flow volume in ventilation, cooling or heating is required (offices, hotel rooms, meeting rooms, health care premises, residentials, etc.)

Highlights

- Damper tightness class 4 according to EN 1751
- Casing tightness class C according to EN 1751
- High measurement/control accuracy of 5 %
- Air volume range of 144 m³/h to 47500 m³/h
- Operating range of pressure drop up to 1000 Pa
- Actuators with quick transition or safety positioning function available
- Insulated version OPTIMA-SI-FC...BM with external insulation for sound reduction

Types of Product

- **OPTIMA-S-FC...BM:** Non-insulated VAV controller
- **OPTIMA-SI-FC...BM:** Insulated VAV controller

Type of Controller

- **BM:** Modbus-RTU or BACnet MS/TP switchable port for communication of all variables, analog setpoint and feedback signals DC 0 (2)V ... 10 V applicable

Types of Actuators

- **S:** Standard actuator
- **Q:** Actuator with short transition time
- **QE:** Actuator with short transition time and electric safety function
- **F:** Actuator with mechanical safety function – spring return

List of Accessories

- **LDR-A:** Sound Attenuator
- **ZTH-EU:** Handheld Tool

- **ZIP-BT-NFC:** Communication Port Bluetooth/NFC

Design

OPTIMA-S-FC...BM consists of a galvanized steel sheet casing, aluminium profile blades with rubber gaskets and a modular VAV control device. OPTIMA-SI-FC...BM is equipped by an insulation for sound reduction. The insulation is a 19 mm thick closed cell foam mat, protected by galvanized steel sheet. The casing contains a robust flanged mounting frame for installation into ducts. The blades are opposed action. The modular VAV control device consists of an aluminium measurement probe, polyurethane measurement impulse tubes, an air flow transmitter, a modular control unit and an actuator. The measurement probe is a special design cross. It is a multi-point averaging flow sensor for accurate air flow readings. The measurement impulse tubes connect the measurement probe with the air flow transmitter.

Actuators

- **S:** Standard actuator
- **Q:** Actuator with short transition time
- **QE:** Actuator with short transition time and electric safety function

The default manufacturer setting of the actuator safety function is **closing after power supply interruption**.

Upon request the manufacturer setting can be changed to **opening after power supply interruption**. Adjustment of intermediate final safety position (0% ... 100% opening) is possible.

The possibility to change the safety function on site is available.

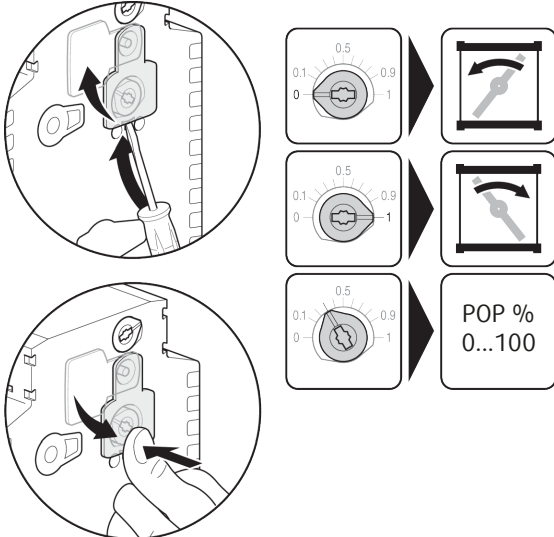

- **F:** Actuator with mechanical safety function – spring return

The default manufacturer setting of the actuator safety function is **closing after power supply interruption**.

Upon request the manufacturer setting can be changed to **opening after power supply interruption**.

		OPTIMA-S(I)-FC...BM																					
		W (mm)																					
		200	250	300	350	400	450	500	550	600	650	700	750	800	850	900	950	1000	1050	1100	1150	1200	
H (mm)	T _{max} (Nm)	100	4	4	4	4	4	4	4	4	4												
	150	4	4	4	4	4	4	4	4	4	4												
	200	4	4	4	4	4	4	4	4	4	4	5	5	5	5	5							
	250			4	4	4	4	4	4	4	4	5	5	5	5	5	5						
	300			4	4	4	4	4	4	4	4	5	5	5	5	5	5	5	5	5			
	350			4	4	4	4	4	4	4	4	5	5	5	5	5	5	5	5	5	5		
	400					4	4	4	4	5	5	5	5	5	5	5	5	5	5	5	6	6	6
	450						4	5	5	5	5	5	5	5	5	5	5	5	6	6	6	6	8
	500							5	5	5	5	5	5	5	5	6	6	6	6	6	6	8	8
	550								5	5	5	5	5	5	6	6	6	6	8	8	8	8	8
	600									5	5	6	6	6	6	6	8	8	8	8	8	8	8
	650										5	6	6	6	6	8	8	8	8	8	8	8	8
	700											6	6	6	8	8	8	8	8	8	8	8	8
	750												6	8	8	8	8	8	8	10	10	10	10
	800													8	8	8	8	8	8	10	10	10	10
	850														8	8	8	8	10	10	10	10	10
900															8	8	8	10	10	10	10	10	
950																10	10	10	10	10	10	10	
1000																	10	10	10	10	10	10	

OPTIMA-S(I)-FC...BM-S/Q/QE/F							
S		Q		QE		F	
4	LM24A-VST	4	LMQ24A-VST	4	NKQ24A-VST	4	LF24A-VST
5		5	NMQ24A-VST	5		5	NF24A-VST
6	NM24A-VST	6		6		6	
8		8	8	8			
10		10	-	10	10		

	\sphericalangle	\odot	$\odot \otimes$	P_r (VA)	P (W)
LM24A-VST	90°	\odot/\odot 120 s	-	4	2,5
NM24A-VST	90°	\odot/\odot 120 s	-	6	3,5
LMQ24A-VST	90°	\odot/\odot 2,5 s	-	25	14,5
NMQ24A-VST	90°	\odot/\odot 4 s	-	25	14,5
SMQ24A-VST	90°	\odot/\odot 7 s	-	28	16,5
NKQ24A-VST	90°	\odot/\odot 4 s	\odot 4 s	24	12,5
LF24A-VST	90°	\odot/\odot 120 s	$\odot < 20$ s	7	4
NF24A-VST	90°	\odot/\odot 120 s	$\odot < 20$ s	10	6,5

Legend

\sphericalangle

Positioning angle

\odot

Transition time

$\odot \otimes$

Transition time without power supply (safety function)

P_r (VA)

Power rating (actuator + controller VRU...)

P (W)

Power consumption in operation (actuator + controller VRU...)

Noise and thermal insulation material for OPTIMA-SI-FC...BM

Base	NBR/PVC
Cellular Structure	Closed
Colour	Black
Density	80 kg/m ³
Water Absorption	2 % < 5 %
Resistance	Air+ U.V.-Good
Thermal Conductivity (t. + 40 °C)	< 0,039 W/m K
	Class 1 (DM 26/06/84)
	UL 94-HF1
Fire Resistance	Class 0 - BS 476 part6-7 UK
	NF certificate n.38 (until mm.32) France
	B-s3,d0 (EN 13501-1) Euroclass
Marine and Shipbuilding	MED B - MED D - DNV type approval
Steam Diffusion	MU > 7.000
Noise Reduction (DIN 4109)	Up to 30 dB
Ecological Compatibility	NO CFC - HCFC, asbest free

Controls

The VAV controllers are equipped by OEM control module and actuator from Belimo. The control units are factory calibrated as standard to the air volume control range $V_{\min} \dots V_{\max}$. The dimension table shows this standard setting. Upon request the control range $V_{\min} \dots V_{\max}$ can be adjusted to customized settings prior to dispatch. The air volumes can also be re-adjusted on site with ZTH-EU hand held service tool. If specific air values for V_{\min} and V_{\max} would be required, this must be indicated prior to order of the units for adequate calibration in the factory.

Modular Control/Actuator Unit Functionality Description

Compact Control/Actuator Unit	Analog Input	BUS Communication	Parameters Setup	Hard Wired Override	Feedback Signal	Feedback Values	Main BUS Com. Variables	Power Supply
BM-S BM-Q BM-QE BM-F	DC 0 V (2 V) ... 10 V	Modbus-RTU BACnet MS/TP	ZTH-EU ZIP-BT-NFC	OPEN, CLOSE, V_{min} , V_{max}	Modbus-RTU BACnet MS/TP DC 0(2) V ... 10 V	Actual volume, Damper angle, Dynamic pressure	Read/write : Setpoint, V_{min} , V_{max} , OPEN, CLOSE Read: Actual volume, damper angle, actual pressure, serial number, fault/alarm messages	AC/DC 24 V

Product Parts

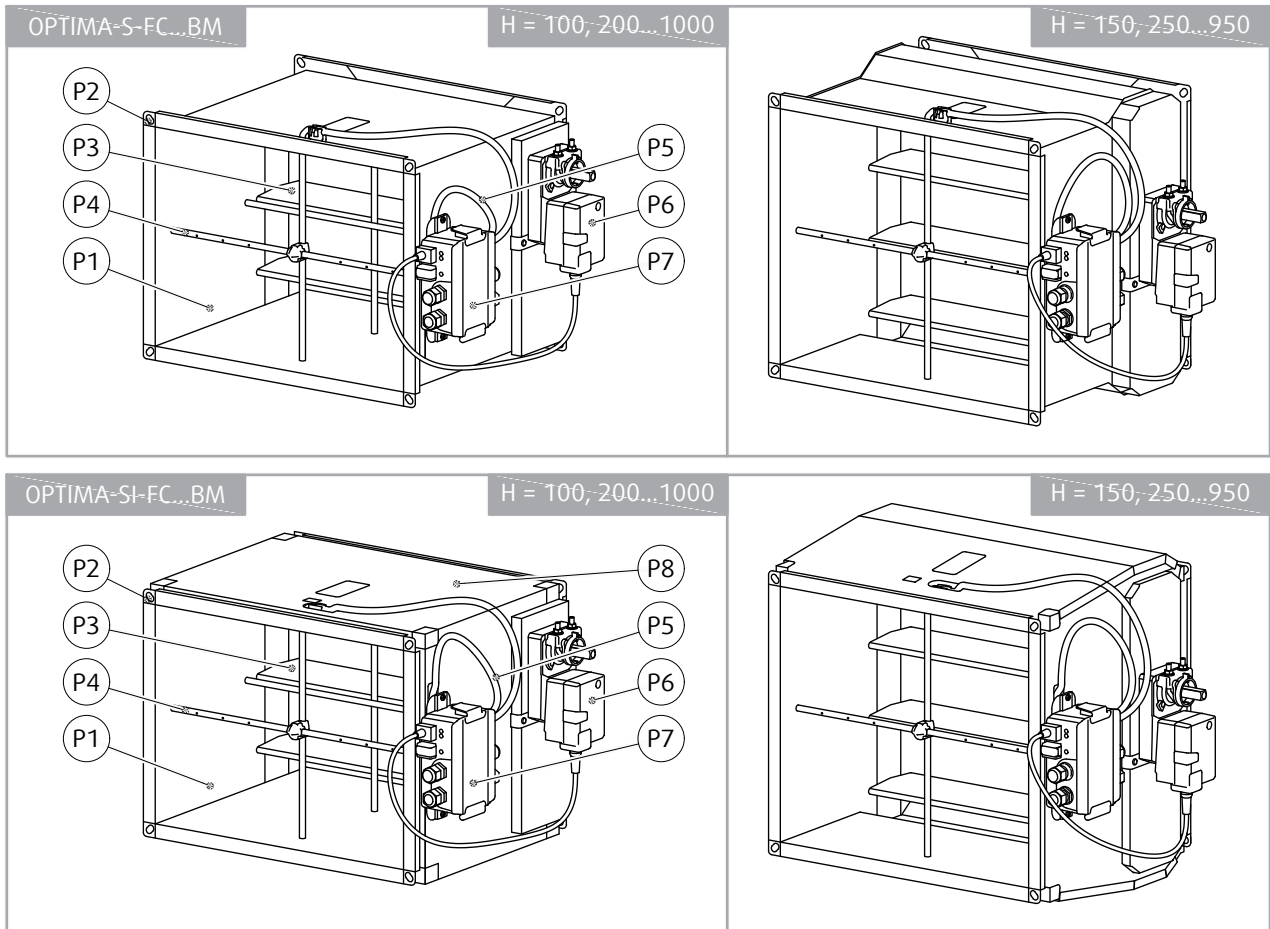

Legend

- P1** Casing
- P2** Duct connection flanges
- P3** Damper blade with gasket
- P4** Measurement probe
- P5** Measurement impulse tubes
- P6** Modular control/actuator unit
- P7** Air flow transmitter
- P8** Insulation

Dimensions & Weights

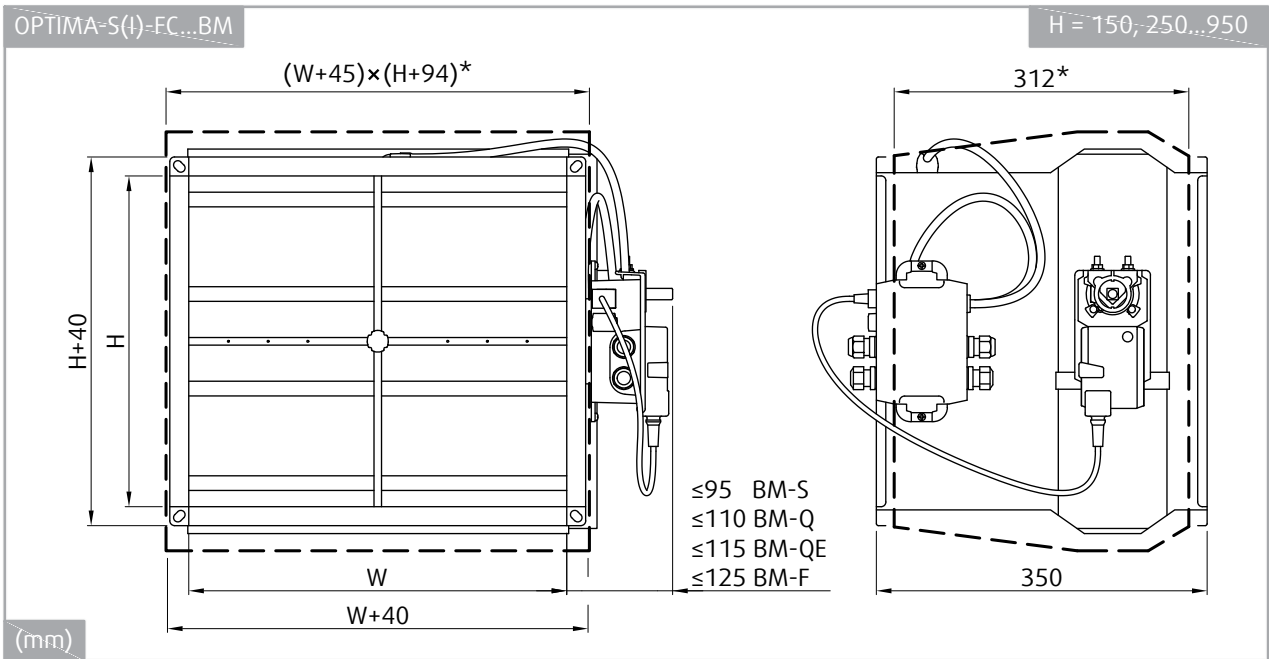
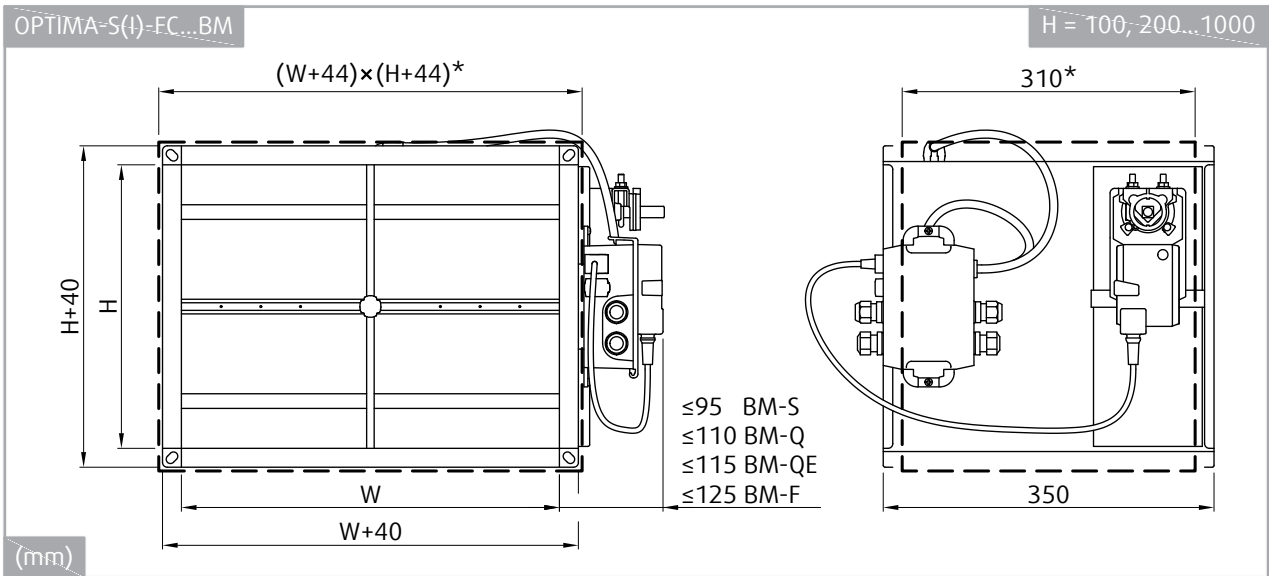

* Insulation

		OPTIMA-S-FC...BM																					
		W (mm)																					
m (kg)		200	250	300	350	400	450	500	550	600	650	700	750	800	850	900	950	1000	1050	1100	1150	1200	
H (mm)	100	2,3	2,3	3,5	4,6	4,6	5,8	5,8	6,9	6,9	-	-	-	-	-	-	-	-	-	-	-	-	
	150	4,6	5,8	5,8	6,9	6,9	6,9	8,1	8,1	9,2	10,4	-	-	-	-	-	-	-	-	-	-	-	
	200	6,9	8,1	8,1	9,2	9,2	9,2	10,4	10,4	11,5	11,5	11,5	12,7	12,7	13,8	13,8	-	-	-	-	-	-	-
	250	-	8,1	8,1	10,4	10,4	10,4	10,4	10,4	11,5	11,5	12,7	13,8	13,8	15,0	16,1	16,1	-	-	-	-	-	-
	300	-	-	9,2	10,4	11,5	10,4	10,4	11,5	11,5	12,7	13,8	15,0	16,1	17,3	21,9	21,9	24,2	24,2	25,3	-	-	-
	350	-	-	10,4	11,5	12,7	11,5	11,5	11,5	12,7	13,8	15,0	16,1	17,3	19,6	21,9	23,0	25,3	25,3	27,6	28,8	-	-
	400	-	-	-	-	13,8	13,8	12,7	12,7	13,8	15,0	16,1	17,3	19,6	21,9	23,0	26,5	28,8	29,9	31,1	32,2	33,4	33,4
	450	-	-	-	-	-	13,8	15,0	15,0	15,0	16,1	18,4	19,6	21,9	24,2	24,2	27,6	29,9	31,1	32,2	33,4	34,5	34,5
	500	-	-	-	-	-	-	17,3	16,1	17,3	18,4	20,7	21,9	24,2	25,3	26,5	28,8	32,2	33,4	34,5	35,7	36,8	36,8
	550	-	-	-	-	-	-	-	18,4	19,6	20,7	23,0	24,2	25,3	27,6	27,6	29,9	33,4	34,5	35,7	36,8	39,1	39,1
	600	-	-	-	-	-	-	-	-	21,9	23,0	24,2	25,3	27,6	28,8	28,8	31,1	34,5	36,8	38,0	39,1	41,4	41,4
	650	-	-	-	-	-	-	-	-	-	25,3	26,5	27,6	28,8	31,1	31,1	33,4	36,8	38,0	40,3	41,4	43,7	43,7
	700	-	-	-	-	-	-	-	-	-	-	28,8	29,9	31,1	33,4	33,4	35,7	39,1	40,3	42,6	43,7	46,0	46,0
	750	-	-	-	-	-	-	-	-	-	-	-	31,1	33,4	34,5	35,7	38,0	41,4	42,6	43,7	46,0	48,3	48,3
	800	-	-	-	-	-	-	-	-	-	-	-	-	34,5	35,7	36,8	39,1	42,6	43,7	46,0	48,3	49,5	49,5
	850	-	-	-	-	-	-	-	-	-	-	-	-	-	36,8	39,1	40,3	43,7	44,9	47,2	49,5	51,8	51,8
900	-	-	-	-	-	-	-	-	-	-	-	-	-	-	40,3	42,6	46,0	47,2	49,5	51,8	54,1	54,1	
950	-	-	-	-	-	-	-	-	-	-	-	-	-	-	-	44,9	47,2	49,5	51,8	54,1	56,4	56,4	
1000	-	-	-	-	-	-	-	-	-	-	-	-	-	-	-	-	49,5	51,8	54,1	56,4	57,5	57,5	

		OPTIMA-SI-FC...BM																					
		W (mm)																					
m (kg)		200	250	300	350	400	450	500	550	600	650	700	750	800	850	900	950	1000	1050	1100	1150	1200	
H (mm)	100	3,5	3,5	5,2	6,9	6,9	8,6	8,6	10,4	10,4	-	-	-	-	-	-	-	-	-	-	-	-	
	150	6,9	8,6	8,6	10,4	10,4	10,4	12,1	12,1	13,8	15,5	-	-	-	-	-	-	-	-	-	-	-	
	200	10,4	12,1	12,1	13,8	13,8	13,8	15,5	15,5	17,3	17,3	17,3	19,0	19,0	20,7	20,7	-	-	-	-	-	-	-
	250	-	12,1	12,1	15,5	15,5	15,5	15,5	15,5	17,3	17,3	19,0	20,7	20,7	22,4	24,2	24,2	-	-	-	-	-	-
	300	-	-	13,8	15,5	17,3	15,5	15,5	17,3	17,3	19,0	20,7	22,4	24,2	25,9	32,8	32,8	36,2	36,2	38,0	-	-	-
	350	-	-	15,5	17,3	19,0	17,3	17,3	17,3	19,0	20,7	22,4	24,2	25,9	29,3	32,8	34,5	38,0	38,0	41,4	43,1	-	-
	400	-	-	-	-	20,7	20,7	19,0	19,0	20,7	22,4	24,2	25,9	29,3	32,8	34,5	39,7	43,1	44,9	46,6	48,3	50,0	50,0
	450	-	-	-	-	-	20,7	22,4	22,4	22,4	24,2	27,6	29,3	32,8	36,2	36,2	41,4	44,9	46,6	48,3	50,0	51,8	51,8
	500	-	-	-	-	-	-	25,9	24,2	25,9	27,6	31,1	32,8	36,2	38,0	39,7	43,1	48,3	50,0	51,8	53,5	55,2	55,2
	550	-	-	-	-	-	-	-	27,6	29,3	31,1	34,5	36,2	38,0	41,4	41,4	44,9	50,0	51,8	53,5	55,2	58,7	58,7
	600	-	-	-	-	-	-	-	-	32,8	34,5	36,2	38,0	41,4	43,1	43,1	46,6	51,8	55,2	56,9	58,7	62,1	62,1
	650	-	-	-	-	-	-	-	-	-	38,0	39,7	41,4	43,1	46,6	46,6	50,0	55,2	56,9	60,4	62,1	65,6	65,6
	700	-	-	-	-	-	-	-	-	-	-	43,1	44,9	46,6	50,0	50,0	53,5	58,7	60,4	63,8	65,6	69,0	69,0
	750	-	-	-	-	-	-	-	-	-	-	-	46,6	50,0	51,8	53,5	56,9	62,1	63,8	65,6	69,0	72,5	72,5
	800	-	-	-	-	-	-	-	-	-	-	-	-	51,8	53,5	55,2	58,7	63,8	65,6	69,0	72,5	74,2	74,2
	850	-	-	-	-	-	-	-	-	-	-	-	-	-	55,2	58,7	60,4	65,6	67,3	70,7	74,2	77,6	77,6
900	-	-	-	-	-	-	-	-	-	-	-	-	-	-	60,4	63,8	69,0	70,7	74,2	77,6	81,1	81,1	
950	-	-	-	-	-	-	-	-	-	-	-	-	-	-	-	67,3	70,7	74,2	77,6	81,1	84,5	84,5	
1000	-	-	-	-	-	-	-	-	-	-	-	-	-	-	-	-	74,2	77,6	81,1	84,5	86,3	86,3	

Ordering Codes

OPTIMA-S-FC...BM

Non-insulated VAV Controller

OPTIMA-S-FC

Nominal Size

W × H

OEM Belimo, Communication Type

BM Switchable: Modbus-RTU or BACnet MS/TP or MP-Bus or analog setpoint/feedback DC 0 (2) V ... 10 V

Actuator Type

S Standard actuator

Q Actuator with short transition time

QE Actuator with short transition time and electric safety function (see availability of the actuator for the chosen dimension in the dimension)

F Actuator with mechanical safety function – spring return

OPTIMA-SI-FC...BM

Insulated VAV Controller

OPTIMA-SI-FC

Nominal Size

W × H

OEM Belimo, Communication Type

BM Switchable: Modbus-RTU or BACnet MS/TP or MP-Bus or analog setpoint/feedback DC 0 (2) V ... 10 V

Actuator Type

S Standard actuator

Q Actuator with short transition time

QE Actuator with short transition time and electric safety function (see availability of the actuator for the chosen dimension in the dimension)

F Actuator with mechanical safety function – spring return

Example of the Ordering Code

OPTIMA-SI-FC-400x300-BM-F

Insulated VAV controller, nominal size 400 mm x 300 mm, with spring return safety function actuator.

NOTES:

Standard setup of the control module is Modbus communication.

Standard setup of the V_{\min} and V_{\max} is indicated in the Quick Selection table. It can be changed upon request, if requested as a note to the order.

Accessories

LDR-A

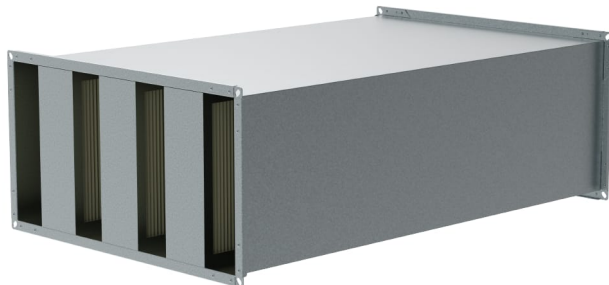

Description

LDR-A is a sound attenuator for rectangular inline devices. The product is intended for installation in rectangular ducts.

Design

LDR-A consists of a frame and attenuation inserts. The frame is manufactured from galvanized steel. The inserts are manufactured from mineral wool.

Product parts

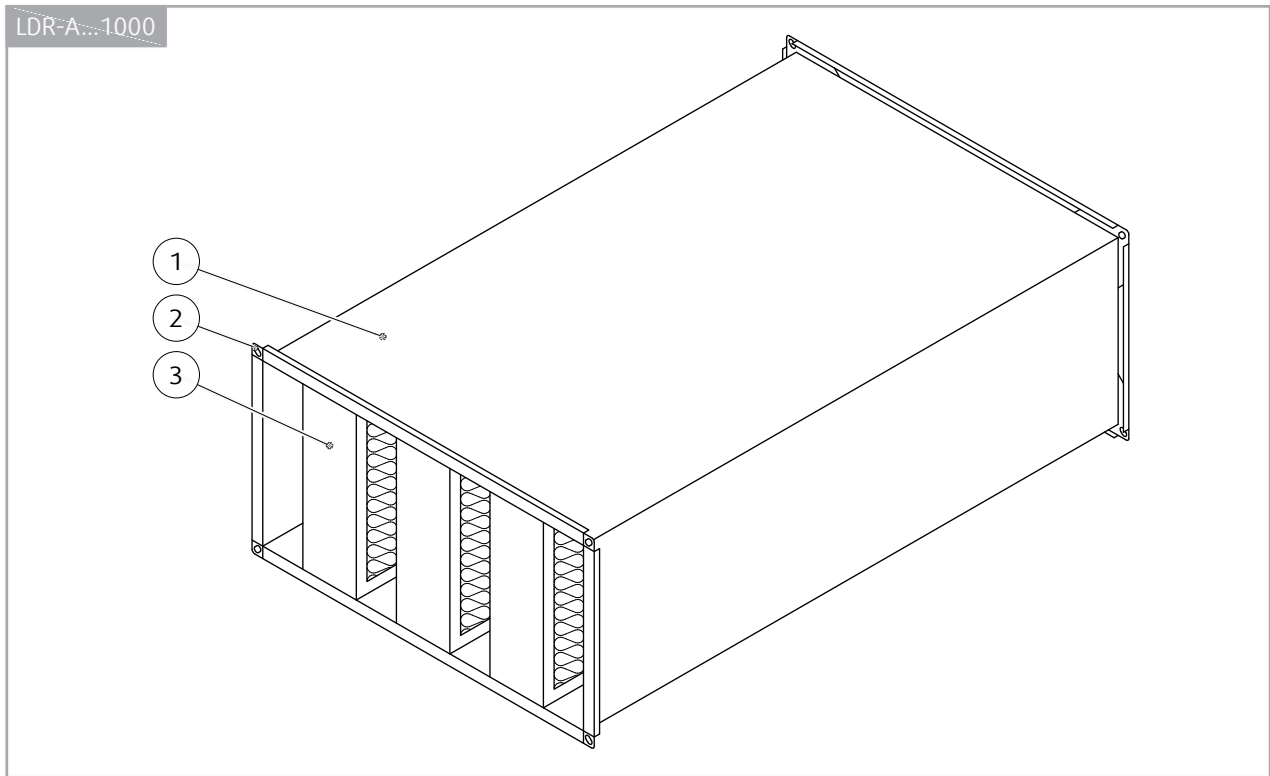

Legend

- P1** - Attenuator casing
- P2** - Connection flange
- P3** - Attenuation baffle

Dimensions

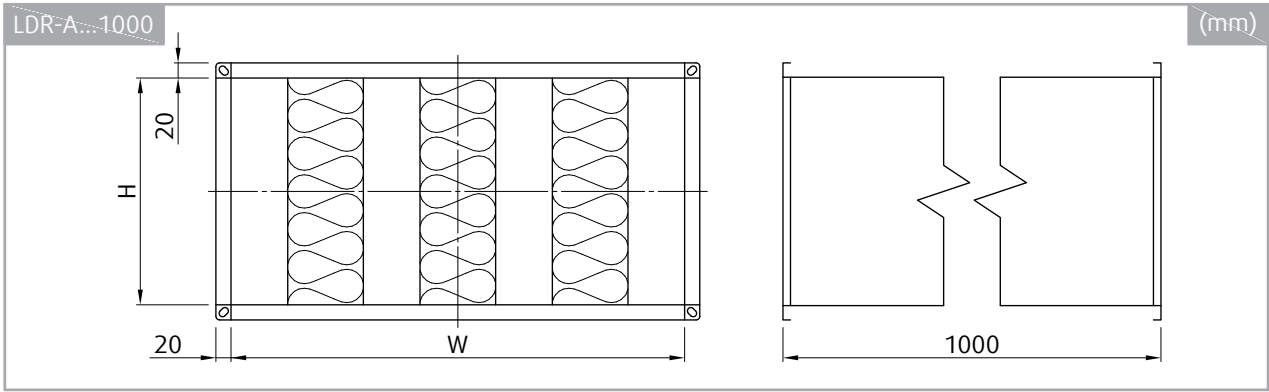

LDR-A			
W	H	L	m
mm			kg
200	100	1000	7
	150	1000	7,5
	200	1000	10,1
250	100	1000	8,4
	150	1000	9,1
	200	1000	11,9
	250	1000	16,2
300	100	1000	9,6
	150	1000	10,9
	200	1000	13,7
	250	1000	18,2
	300	1000	19,2
	350	1000	20,1
350	100	1000	10,9
	150	1000	12,7
	200	1000	15,5
	250	1000	20,3
	300	1000	21,2
	350	1000	22,2
400	100	1000	12,1
	150	1000	14,5
	200	1000	17,3
	250	1000	22,4
	300	1000	23,3
	350	1000	24,3
	400	1000	25,7

LDR-A			
W	H	L	m
mm			kg
450	100	1000	13,4
	150	1000	16,3
	200	1000	19,1
	250	1000	24,4
	300	1000	25,3
	350	1000	26,3
	400	1000	27,8
500	450	1000	28,9
	100	1000	14,6
	150	1000	18,1
	200	1000	20,9
	250	1000	26,5
	300	1000	27,4
	350	1000	28,4
	400	1000	29,1
550	450	1000	31,1
	500	1000	32,3
	100	1000	15,9
	150	1000	19,9
	200	1000	22,7
	250	1000	28,5
	300	1000	29,5
	350	1000	30,4
	400	1000	32,1
	450	1000	33,2
500	1000	34,4	
550	1000	38,1	

LDR-A			
W	H	L	m
mm			kg
600	100	1000	17,1
	150	1000	21,7
	200	1000	24,5
	250	1000	30,6
	300	1000	31,5
	350	1000	32,5
	400	1000	34,3
	450	1000	35,4
	500	1000	36,6
	550	1000	40,6
650	150	1000	23,5
	200	1000	26,3
	250	1000	32,7
	300	1000	33,6
	350	1000	34,6
	400	1000	36,4
	450	1000	37,5
	500	1000	38,7
	550	1000	43,1
	600	1000	44,5
750	250	1000	36,8
	300	1000	37,7
	350	1000	38,7
	400	1000	40,7
	450	1000	41,8
	500	1000	42,1
	550	1000	48,1
	600	1000	49,5
	650	1000	53,1
	700	1000	57,1
750	1000	59,6	

LDR-A			
W	H	L	m
mm			kg
850	200	1000	33,4
	250	1000	40,8
	300	1000	41,7
	350	1000	42,7
	400	1000	44,9
	450	1000	46,0
	500	1000	47,2
	550	1000	53,0
	600	1000	54,4
	650	1000	58,5
	700	1000	63,1
	750	1000	65,6
	800	1000	71,3
	850	1000	73,1
	900	200	1000
250		1000	42,1
300		1000	43,9
350		1000	44,9
400		1000	47,2
450		1000	48,3
500		1000	49,5
550		1000	55,6
600		1000	56,1
650		1000	61,2
700		1000	66,1
750		1000	68,6
800	1000	74,6	
850	1000	76,4	
900	1000	78,4	

LDR-A			
W	H	L	m
mm			kg
950	250	1000	44,1
	300	1000	45,1
	350	1000	46,1
	400	1000	49,3
	450	1000	50,4
	500	1000	51,6
	550	1000	58,1
	600	1000	59,5
	650	1000	63,9
	700	1000	69,1
	750	1000	71,6
	800	1000	77,9
	850	1000	79,7
	900	1000	81,7
950	1000	83,9	
1000	300	1000	47,1
	350	1000	48,1
	400	1000	51,5
	450	1000	52,6
	500	1000	53,8
	550	1000	60,6
	600	1000	61,1
	650	1000	66,6
	700	1000	72,1
	750	1000	74,6
	800	1000	81,2
	850	1000	82,1
	900	1000	84,1
	950	1000	87,2
1000	1000	89,4	

LDR-A			
W	H	L	m
mm			kg
1050	300	1000	50,1
	350	1000	51,1
	400	1000	53,6
	450	1000	54,7
	500	1000	55,9
	550	1000	63,1
	600	1000	64,5
	650	1000	69,3
	700	1000	75,1
	750	1000	77,6
	800	1000	84,5
	850	1000	86,3
	900	1000	88,3
	950	1000	90,5
1000	1000	92,7	
1100	300	1000	52,2
	350	1000	53,1
	400	1000	55,8
	450	1000	56,9
	500	1000	58,1
	550	1000	65,6
	600	1000	66,1
	650	1000	71,1
	700	1000	78,1
	750	1000	80,6
	800	1000	87,8
	850	1000	89,6
	900	1000	91,6
	950	1000	93,8
1000	1000	95,1	

LDR-A			
W	H	L	m
mm			kg
1150	350	1000	55,2
	400	1000	57,9
	450	1000	58,1
	500	1000	60,2
	550	1000	68,1
	600	1000	69,5
	650	1000	74,7
	700	1000	81,1
	750	1000	83,6
	800	1000	91,1
	850	1000	92,9
	900	1000	94,9
	950	1000	97,1
	1000	1000	99,3
1200	400	1000	60,1
	450	1000	61,2
	500	1000	62,4
	550	1000	70,6
	600	1000	71,1
	650	1000	77,4
	700	1000	84,1
	750	1000	86,6
	800	1000	94,4
	850	1000	96,2
	900	1000	98,2
	950	1000	100,4
1000	1000	102,6	

ZTH-EU

Handheld Tool



ZTH-EU is a handheld tool for VAV controllers and communicative actuators. The product enables the customer to change the configuration of the VAV controllers.

ZIP-BT-NFC

Communication Port Bluetooth/NFC



ZIP-BT-NFC is a wireless interface connecting the smartphone with configuration app Belimo Assistant via Bluetooth to the VAV controller VRU... with NFC communication protocol.

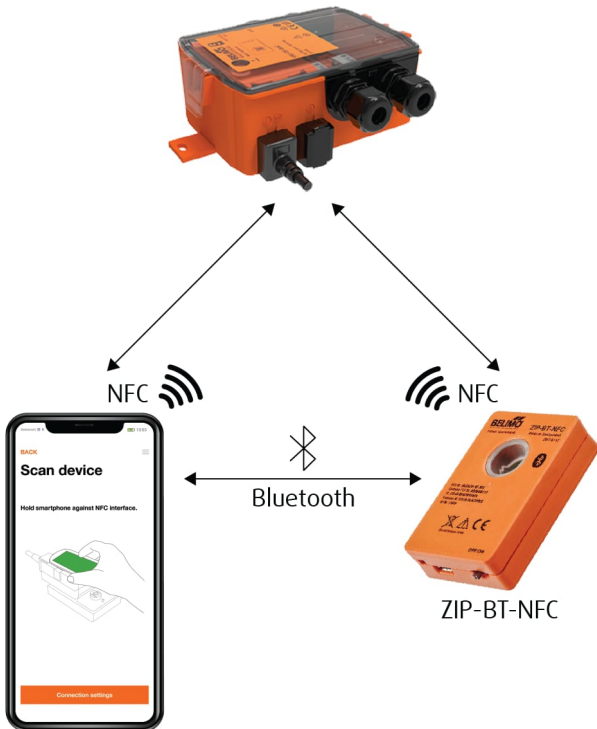

Configuration with ZTH-EU or by Belimo Assistant app via NFC or via Bluetooth through ZIP BT NFC

Parametrisation

			Tool		Authorisation
Parameter/Function	Unit/Value	Function/Description/ (Area)	Assistant App	ZTH-EU	Expert/OEM
VAV Unit/Air Duct Pressure Control Butterfly Valve - Manufacturer Parameters (OEM Values - Not Variable)					
OSN Actuator	xxxxx-xxxxx-xxx-xxx	Actuator series number	r	-	
Rotation Direction	CCW/CW	Actuator direction of rotation setting	r/w	-	E
Range of rotation	Adapted/programmed	Actuator adapted/programmed 30°...95°	r/w	-	E
Power on behaviour	No action/synch. / adaption	Actuator power on behaviour	r/w	-	E
Parametrisation - Project-specific Settings					
Position	Text string	Plant designation (64 Z./ZTH 16 Z.)	r/w	r	
Max	m ³ /h l/s cfm (PC-tool/ ZTH %) % (position)	Operating volumetric flow 0% ... 100% V _{nom} Damper position (pos. ctrl.) 0% ... 100%	r/w	r/w	
Min	m ³ /h l/s cfm (PC-tool/ ZTH %) % (position)	Operating volumetric flow 0% ... 100% V _{nom} Damper position (pos. ctrl.) 0% ... 100%	r/w	r/w	
Altitude compensation	ON/OFF	Switch function ON/OFF	r/w	-	E
Altitude of installation	0 m	Compensated Δp and volumetric flow values to set the altitude of installation (above sea level)	r/w	-	E
Function	VAV-CAV/position control	Control function	r/w	-	E
Room pressure cascade	ON/OFF	VAV: secondary circuit room pressure cascade	r/w	-	E
Setpoint	Analogue/bus	Analogue and hybrid mode/bus	r/w	-	E
Setpoint offset	0	VAV: ±5% compensation ABL unit	r/w	-	E
Reference signal Y	2 V ... 10 V/0 V ... 10 V/ adjustable	Setting for VAV control	r/w	-	E
Feedback type	Volumetric flow/Δp/ position	VAV: volume/Δp/damper position Pressure: Δp/damper position	r/w	-	E
Feedback U	2 V ... 10 V/0 V ... 10 V/ adjustable	Setting U signal	r/w	-	E

Bus parameter

			Tool		Authorisation
Parameter/Function	Unit/Value	Function/Description/ (Area)	Assistant App	ZTH-EU	Expert/OEM
Parametrisation – Communication					
Bus protocol	BACnet MS/TP / Modbus / MP		r/w	–	E
Bus protocol	BACnet MS/TP				
MAC address	0...127		r/w	–	E
Baudrate	9600 / ... / 115200		r/w	–	E
Terminating resistor	OFF/ON		r/w	–	E
Instance number	1...4194304		r/w	–	E
Device name	VAV universal	(32 Z.)	r/w	–	E
Max master	1...127		r/w	–	E
Bus protocol	Modbus RTU				
Address	1...247		r/w	–	E
Baudrate	9600 / ... / 115200		r/w	–	E
Terminating resistor	OFF/ON		r/w	–	E
Parity	1-8-N-2/...E-1/...-0-1/...- N-1		r/w	–	E
Bus protocol	MP-Bus				
MP address	PP/MP1...8	PP (MP off)/MP1...8	r/w	–	E
Bus fail position	0	0% ... 100% (min...max)	r/w	–	E
Compatibility mode	Default/VRP-M	Default: Belimo MP datapool device VRP-M: VRP-M replacement in existing MP system	r/w	–	E

Legend**X** Application supports function**r** Tool: read**w** Tool: write

– Tool: Does not support parameter

E Only visible in Expert Mode Authorisations - functionally relevant settings are only accessible via the Expert Level of the Belimo Assistant App.

Quick Selection

NOTES:

* Standard setup of the V_{min} is adjusted corresponding to air flow velocity 2 m/s and standard setup of the V_{max} is adjusted corresponding to air flow velocity 9 m/s. It can be changed upon request, if stated in the ordering code.

The V_{min} can be adjusted from 0 m³/h to V_{nom} value from the table below.

The V_{max} can be adjusted from 20 % to 100 % of the V_{nom} value from the table below.

W	H	V _{nom} @ 11 m/s	V _{min} @ 2 m/s	V _{max} @ 9 m/s
mm		m ³ /h		
200	100	792	144	648
	150	1188	216	972
	200	1584	288	1296
250	100	990	180	810
	150	1485	270	1215
	200	1980	360	1620
	250	2475	450	2025
300	100	1188	216	972
	150	1782	324	1458
	200	2376	432	1944
	250	2970	540	2430
	300	3564	648	2916
350	350	4158	756	3402
	100	1386	252	1134
	150	2079	378	1701
	200	2772	504	2268
	250	3465	630	2835
	300	4158	756	3402
400	350	4851	882	3969
	100	1584	288	1296
	150	2376	432	1944
	200	3168	576	2592
	250	3960	720	3240
	300	4752	864	3888
	350	5544	1008	4536
450	400	6336	1152	5184
	100	1782	324	1458
	150	2673	486	2187
	200	3564	648	2916
	250	4455	810	3645
	300	5346	972	4374
	350	6237	1134	5103
	400	7128	1296	5832
450	8019	1458	6561	

W	H	V _{nom} @ 11 m/s	V _{min} @ 2 m/s	V _{max} @ 9 m/s
mm		m ³ /h		
500	100	1980	360	1620
	150	2970	540	2430
	200	3960	720	3240
	250	4950	900	4050
	300	5940	1080	4860
	350	6930	1260	5670
	400	7920	1440	6480
550	450	8910	1620	7290
	500	9900	1800	8100
	100	2178	396	1782
	150	3267	594	2673
	200	4356	792	3564
	250	5445	990	4455
	300	6534	1188	5346
	350	7623	1386	6237
600	400	8712	1584	7128
	450	9801	1782	8019
	500	10890	1980	8910
	550	11979	2178	9801
	100	2376	432	1944
	150	3564	648	2916
	200	4752	864	3888
	250	5940	1080	4860
	300	7128	1296	5832
	350	8316	1512	6804
650	400	9504	1728	7776
	450	10692	1944	8748
	500	11880	2160	9720
	550	13068	2376	10692
	600	14256	2592	11664

W	H	V _{nom} @ 11 m/s	V _{min} @ 2 m/s	V _{max} @ 9 m/s
mm		m ³ /h		
650	150	3861	702	3159
	200	5148	936	4212
	250	6435	1170	5265
	300	7722	1404	6318
	350	9009	1638	7371
	400	10296	1872	8424
	450	11583	2106	9477
	500	12870	2340	10530
	550	14157	2574	11583
	600	15444	2808	12636
650	16731	3042	13689	
700	200	5544	1008	4536
	250	6930	1260	5670
	300	8316	1512	6804
	350	9702	1764	7938
	400	11088	2016	9072
	450	12474	2268	10206
	500	13860	2520	11340
	550	15246	2772	12474
	600	16632	3024	13608
	650	18018	3276	14742
700	19404	3528	15876	
750	200	5940	1080	4860
	250	7425	1350	6075
	300	8910	1620	7290
	350	10395	1890	8505
	400	11880	2160	9720
	450	13365	2430	10935
	500	14850	2700	12150
	550	16335	2970	13365
	600	17820	3240	14580
	650	19305	3510	15795
700	20790	3780	17010	
750	22275	4050	18225	

W	H	V _{nom} @ 11 m/s	V _{min} @ 2 m/s	V _{max} @ 9 m/s
mm		m ³ /h		
800	200	6336	1152	5184
	250	7920	1440	6480
	300	9504	1728	7776
	350	11088	2016	9072
	400	12672	2304	10368
	450	14256	2592	11664
	500	15840	2880	12960
	550	17424	3168	14256
	600	19008	3456	15552
	650	20592	3744	16848
700	22176	4032	18144	
750	23760	4320	19440	
800	25344	4608	20736	
850	200	6732	1224	5508
	250	8415	1530	6885
	300	10098	1836	8262
	350	11781	2142	9639
	400	13464	2448	11016
	450	15147	2754	12393
	500	16830	3060	13770
	550	18513	3366	15147
	600	20196	3672	16524
	650	21879	3978	17901
700	23562	4284	19278	
750	25245	4590	20655	
800	26928	4896	22032	
850	28611	5202	23409	

W	H	V _{nom} @ 11 m/s	V _{min} @ 2 m/s	V _{max} @ 9 m/s
mm		m ³ /h		
900	200	7128	1296	5832
	250	8910	1620	7290
	300	10692	1944	8748
	350	12474	2268	10206
	400	14256	2592	11664
	450	16038	2916	13122
	500	17820	3240	14580
	550	19602	3564	16038
	600	21384	3888	17496
	650	23166	4212	18954
	700	24948	4536	20412
	750	26730	4860	21870
	800	28512	5184	23328
	850	30294	5508	24786
900	32076	5832	26244	
950	250	9405	1710	7695
	300	11286	2052	9234
	350	13167	2394	10773
	400	15048	2736	12312
	450	16929	3078	13851
	500	18810	3420	15390
	550	20691	3762	16929
	600	22572	4104	18468
	650	24453	4446	20007
	700	26334	4788	21546
	750	28215	5130	23085
	800	30096	5472	24624
	850	31977	5814	26163
	900	33858	6156	27702
950	35739	6498	29241	

W	H	V _{nom} @ 11 m/s	V _{min} @ 2 m/s	V _{max} @ 9 m/s
mm		m ³ /h		
1000	300	11880	2160	9720
	350	13860	2520	11340
	400	15840	2880	12960
	450	17820	3240	14580
	500	19800	3600	16200
	550	21780	3960	17820
	600	23760	4320	19440
	650	25740	4680	21060
	700	27720	5040	22680
	750	29700	5400	24300
	800	31680	5760	25920
	850	33660	6120	27540
	900	35640	6480	29160
	950	37620	6840	30780
1000	39600	7200	32400	
1050	300	12474	2268	10206
	350	14553	2646	11907
	400	16632	3024	13608
	450	18711	3402	15309
	500	20790	3780	17010
	550	22869	4158	18711
	600	24948	4536	20412
	650	27027	4914	22113
	700	29106	5292	23814
	750	31185	5670	25515
	800	33264	6048	27216
	850	35343	6426	28917
	900	37422	6804	30618
	950	39501	7182	32319
1000	41580	7560	34020	

W	H	V _{nom} @ 11 m/s	V _{min} @ 2 m/s	V _{max} @ 9 m/s
mm		m ³ /h		
1100	300	13068	2376	10692
	350	15246	2772	12474
	400	17424	3168	14256
	450	19602	3564	16038
	500	21780	3960	17820
	550	23958	4356	19602
	600	26136	4752	21384
	650	28314	5148	23166
	700	30492	5544	24948
	750	32670	5940	26730
	800	34848	6336	28512
	850	37026	6732	30294
	900	39204	7128	32076
	950	41382	7524	33858
	1000	43560	7920	35640
	1150	350	15939	2898
400		18216	3312	14904
450		20493	3726	16767
500		22770	4140	18630
550		25047	4554	20493
600		27324	4968	22356
650		29601	5382	24219
700		31878	5796	26082
750		34155	6210	27945
800		36432	6624	29808
850		38709	7038	31671
900		40986	7452	33534
950	43263	7866	35397	
1000	45540	8280	37260	

W	H	V _{nom} @ 11 m/s	V _{min} @ 2 m/s	V _{max} @ 9 m/s
mm		m ³ /h		
1200	400	19008	3456	15552
	450	21384	3888	17496
	500	23760	4320	19440
	550	26136	4752	21384
	600	28512	5184	23328
	650	30888	5616	25272
	700	33264	6048	27216
	750	35640	6480	29160
	800	38016	6912	31104
	850	40392	7344	33048
	900	42768	7776	34992
	950	45144	8208	36936
	1000	47520	8640	38880

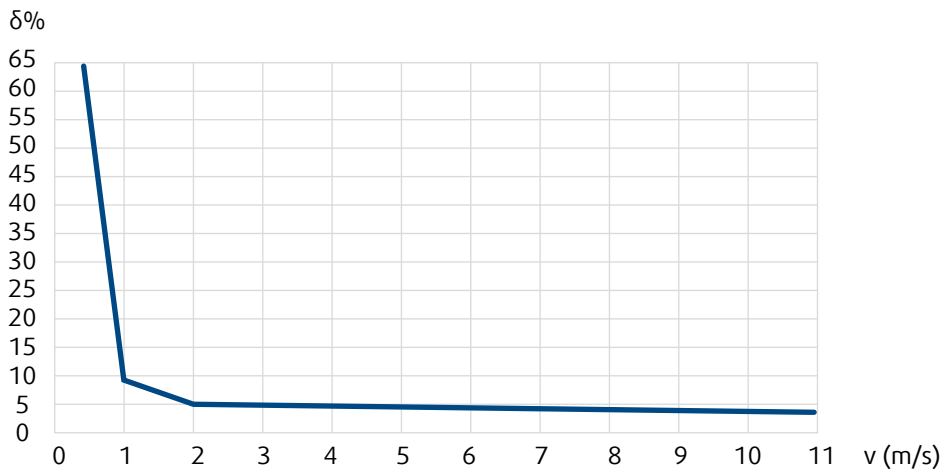

Typical max. absolute control deviation δ from actual air flow dependent on the air flow velocity v in the duct

Technical Parameters

Diagrams and technical parameters are available at design.systemair.com

Installation

OPTIMA-S(I)-FC...BM

$$D_{\text{eff}} = (2 \times W \times H) / (W + H)$$

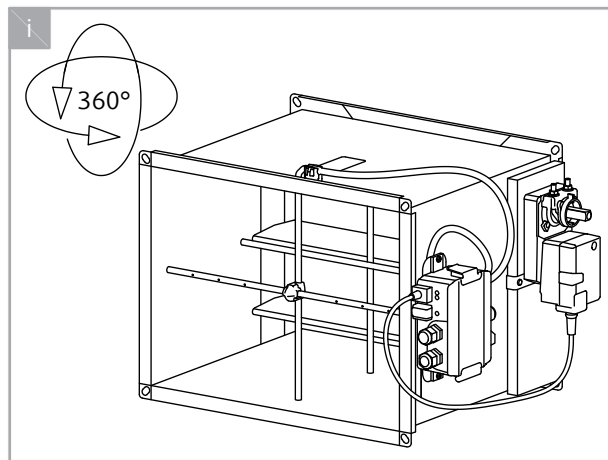
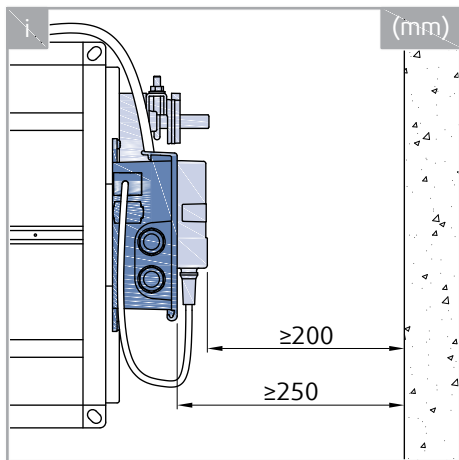
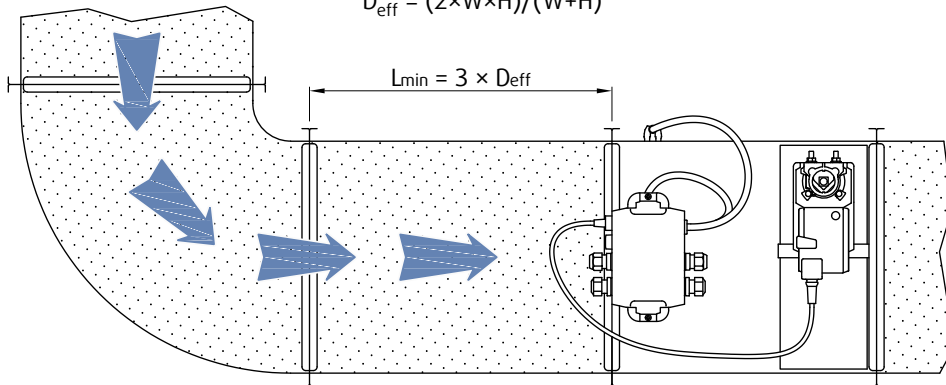

Electrical Connections

AC/DC 24 V, modulating (VAV)

The VAV controller operates with setpoint adjusted through analog input signal (terminal 3) and feedback signal (terminal 5).

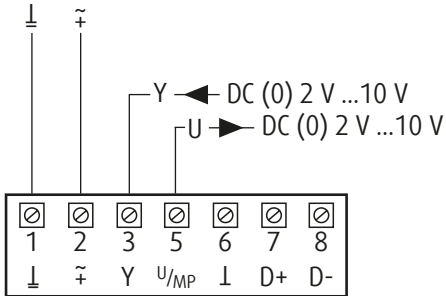

Additional functions can be activated by connecting the override inputs z1 and z2.

The priority of these functions is higher than the VAV modulating operation with analog input.

Override control z1

Contact 11-9 = Motor STOP

Contact 11-10 = Damper OPEN

Override control z2

Contact 12-13 = Damper CLOSED

Contact 12-14 = V_{\max}

11 and 12 without contact = no priority override through z1 or z2

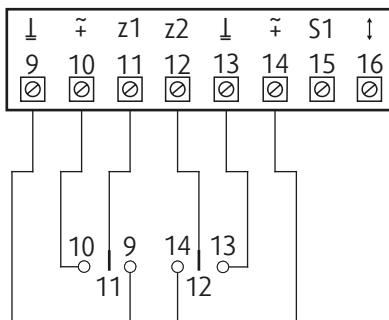

Priority rule - Analog VAV-control

1. z1
2. z2
3. a) adaption (autonomous initializing controller function)
4. b) synchronisation (autonomous initializing controller function)
5. Y-Modulating: $V_{\min} \dots V_{\max}$ (through analog input)

AC/DC 24 V, contactor step control (CAV)

The VAV controller operates with setpoint in discrete steps generated by different potentials connected to the analog input (terminal 3) and analog feedback signal (terminal 5).

Contact 2-3 = V_{max}

3 not connected = V_{min}

Contact 1-3 = damper CLOSE (control signal mode 2...10V)

Contact 1-3 = V_{min} (control signal mode 0...10 V)

The control signal mode can be adjusted in the VAV controller by the handheld configuration tool ZTH-EU.

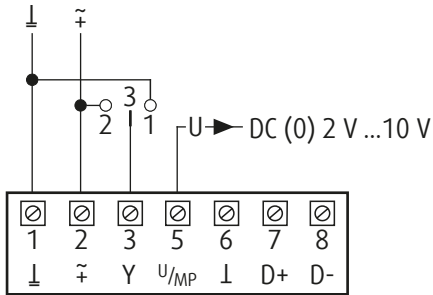

Additional functions can be activated by connecting the override inputs z1 and z2.

The priority of these functions is higher than the VAV modulating operation with analog input.

Override control z1

Contact 11-9 = Motor STOP

Contact 11-10 = Damper OPEN

Override control z2 Contact 12-13 = Damper CLOSED

Contact 12-14 = V_{max}

11 and 12 without contact = no priority override through z1 or z2

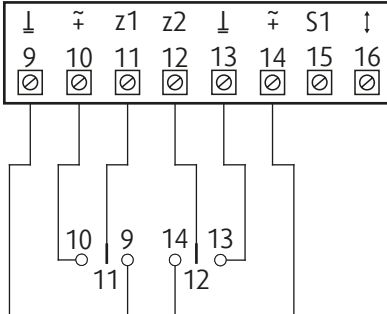

Priority rule - Step-Control

1. z1
2. z2
3. a) adaption (autonomous initializing controller function)
4. b) synchronisation (autonomous initializing controller function)
5. Y-Step Control: Close - V_{min} - V_{max} (through analog input)

BACnet MS/TP or Modbus RTU

(This operation mode requires parametrization)

VAV control in $V_{min} \dots V_{max}$ range and other functionalities with all variables communicated through bus (terminals 7, 8)
 – by Modbus or BACnet protocol.

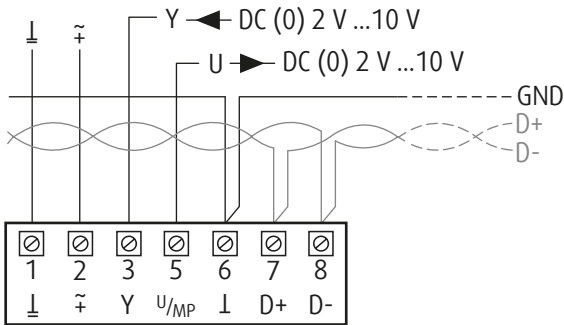

Additional functions can be activated by connecting the override inputs z1 and z2.

The priority of these functions is higher than the VAV modulating operation with analog input.

Override control z1

Contact 11-9 = Motor STOP

Contact 11-10 = Damper OPEN

Override control z2

Contact 12-13 = Damper CLOSED

Contact 12-14 = V_{max}

11 and 12 without contact = no priority override through z1 or z2

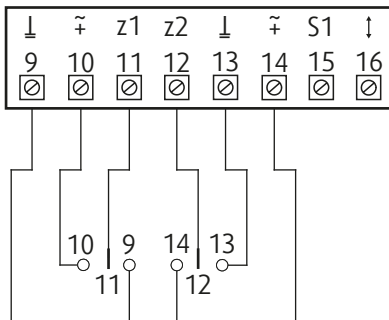

Priority rule – BACnet / Modbus Control

1. z1
2. z2
3. Bus Watchdog
4. a) adaption (autonomous initializing controller function)
5. b) synchronisation (autonomous initializing controller function)
6. Bus Override
7. Bus Setpoint: $V_{min} - V_{max}$

BACnet MS/TP or Modbus RTU with analog setpoint (hybrid mode)

(This operation mode requires parametrization)

VAV control in $V_{\min} \dots V_{\max}$ range and other functionalities with setpoint reading through analog input (terminal 3) and feedback through analog output (terminal 5). All other variables are communicated through bus (terminals 7, 8) – by Modbus or BACnet protocol.

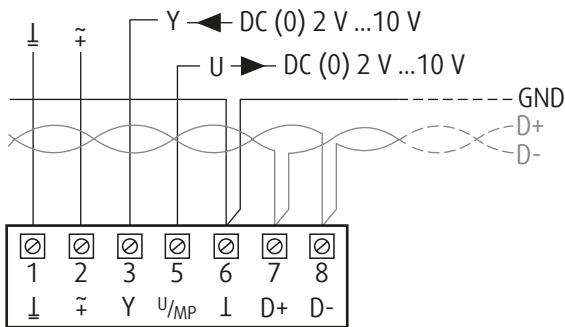

Additional functions can be activated by connecting the override inputs z1 and z2.

The priority of these functions is higher than the VAV modulating operation with analog input.

Override control z1

Contact 11-9 = Motor STOP

Contact 11-10 = Damper OPEN

Override control z2

Contact 12-13 = Damper CLOSED

Contact 12-14 = V_{\max}

11 and 12 without contact = no priority override through z1 or z2

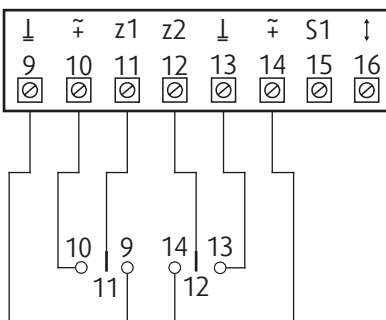

Priority rule – BACnet / Modbus Control

1. z1
2. z2
3. Bus Watchdog
4. a) adaption (autonomous initializing controller function)
5. b) synchronisation (autonomous initializing controller function)
6. Bus Override
7. Y-Step Control: Close – V_{\min} - V_{\max} (through analog input – see wiring for AC/DC 24V Step Control)
8. Y-Modulating: $V_{\min} \dots V_{\max}$ (through analog input – see wiring for Modulating VAV)

MP-Bus

(This operation mode requires parametrization)

VAV control in $V_{\min} \dots V_{\max}$ range and other functionalities with all variables communicated through bus (terminals 1, 2, 5) – by MP-Bus protocol.

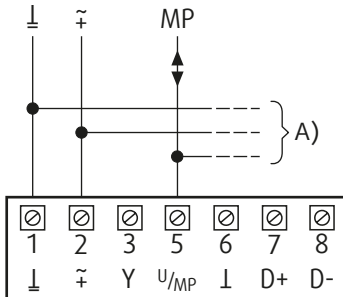

Additional functions can be activated by connecting the override inputs z1 and z2.

The priority of these functions is higher than the VAV modulating operation with analog input.

Override control z1

Contact 11-9 = Motor STOP

Contact 11-10 = Damper OPEN

Override control z2

Contact 12-13 = Damper CLOSED

Contact 12-14 = V_{\max}

11 and 12 without contact = no priority override through z1 or z2

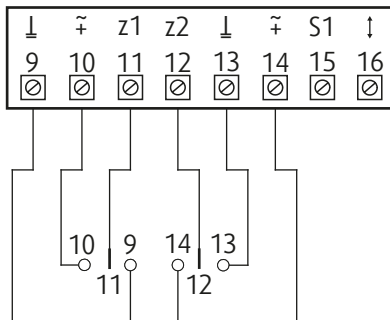

Priority rule – BACnet / Modbus Control

1. z1
2. z2
3. Bus Watchdog
4. a) adaption (autonomous initializing controller function)
5. b) synchronisation (autonomous initializing controller function)
6. Y-Step Control: Close – $V_{\min} - V_{\max}$ (through analog input – see wiring for AC/DC 24V Step Control)
7. Bus Override
8. Bus Setpoint: $V_{\min} - V_{\max}$

Connection of passive sensor

(Available in bus operation)

The value measured by the passive sensor can be communicated as a variable by bus.

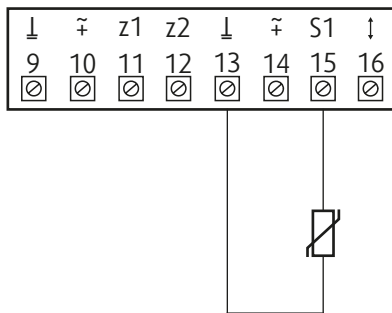

Suitable for Ni1000 and Pt1000

Connection of active sensor

(Available in bus operation)

The value measured by the active sensor can be communicated as a variable by bus.

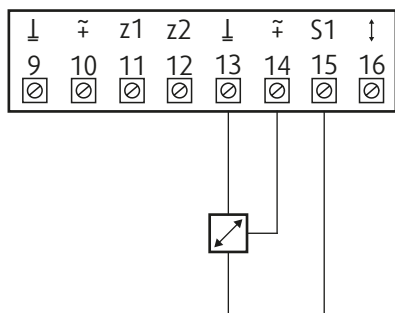

Possible input voltage range:

DC 0...10 V (resolution 5 mV)

Example:

- Active temperature sensors
- setpoint generator
- humidity sensor

Connection switching contact

(Available in bus operation)

The binary value of the switching contact can be communicated as a variable by bus.

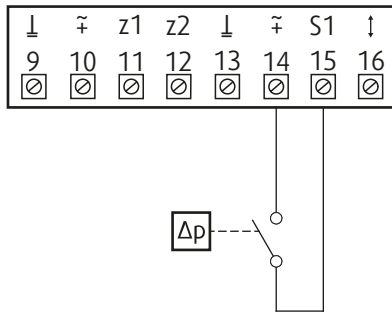

Requirements switching contact: The switch must be capable of switching a current of 10 mA @ 24 V cleanly.

Example:

- dP sensor
- window contact

Transport, Storage and Operation

Transport and storage temperature range: -20 °C to +40 °C, dry indoor conditions.

Operation temperature range: -20 °C ... +70 °C in the duct, -20 °C ... +50 °C on the actuator.

Supplement

Any deviations from the technical specifications contained herein and the terms should be discussed with the manufacturer. We reserve the right to make any changes to the product without prior notice, provided that these changes do not affect the quality of the product and the required parameters.

Current information on all products is available on design.systemair.com.

